

## CHAPTER 2

# MODELING CONCEPTS

### 2.1 Introduction

As was discussed in the previous chapter, in order to apply optimization methods we must have a model to optimize. As we also mentioned, obtaining a good model of the design problem is the most important step in optimization. In this chapter we discuss some modeling concepts that can help you develop models which can successfully be optimized. We also discuss the formulation of objectives and constraints for some special situations. We look at how graphics can help us understand the nature of the design space and the model. We end with an example optimization of a heat pump.

### 2.2 Physical Models vs. Experimental Models

Two types of models are often used with optimization methods: physical models and experimental models. Physical models are based on the underlying physical principles that govern the problem. Experimental models are based on models of experimental data. Some models contain both physical and experimental elements. We will discuss both types of models briefly.

#### 2.2.1 Physical Models

Physical models can be either analytical or numerical in nature. For example, the two-bar truss is an analytical, physical model. The equations are based on modeling the physical phenomena of stress, buckling stress and deflection. The equations are all closed form, analytical expressions. If we used numerical methods, such as the finite element method, to solve for the solution to the model, we would have a numerical, physical model.

#### 2.2.2 Experimental Models

Experimental models are based on experimental data. A functional relationship for the data is proposed and fit to the data. If the fit is good, the model is retained; if not, a new relationship is used. For example if we wish to find the friction factor for a pipe, we could refer to the Moody chart, which is based on experimental data, or use expressions based on a curve fit of the data.

### 2.3 Modeling Considerations

#### 2.3.1 Making the Model Robust

During optimization, the algorithms will move through the design space seeking an optimum. Sometimes the algorithms will generate unanticipated designs during this process. To have a successful optimization, the model must be able to handle these designs, i.e. it must be *robust*. Before optimizing, you should consider if there are there any designs for which the model is undefined. If such designs exist, you need to take steps to insure either that 1) the

optimization problem is defined such that the model will never see these designs, or 2) the model is made “bulletproof” so it can survive these designs.

For example, for the two-bar truss, the truss becomes undefined if the diameter or thickness go to zero. Although unlikely to ever happen, we can insure this does not occur by defining non-zero lower bounds for these variables—the algorithms should never violate upper or lower bounds. (This is not true of functional constraints, however, which the algorithms sometimes will violate during the search for an optimum.)

The above case seems a little farfetched, in that truss with a zero thickness or diameter would not make any sense. However, sometimes models can crash for designs that do make sense. Example 2.3.1.1 presents such a case.

### 2.3.1.1 Example: Log Mean Temperature Difference

In the design of a shell and tube heat exchanger, the average temperature difference across the exchanger is given by the log mean temperature difference:

$$\Delta T_{LMTD} = \frac{(T_{h2} - T_{c2}) - (T_{h1} - T_{c1})}{\ln[(T_{h2} - T_{c2}) / (T_{h1} - T_{c1})]} \quad (2.1)$$

where  $(T_{h2} - T_{c2})$  is, for example, the difference in the temperature of the hot and cold fluids at one end of the exchanger, denoted by subscript 2. This difference is sometimes called the “temperature of approach.” A perfectly legitimate case is to have the temperature of approach at both ends of the exchanger be the same, i.e.,

$$(T_{h2} - T_{c2}) = (T_{h1} - T_{c1}) \quad (2.2)$$

in which case the denominator becomes  $\ln[1] = 0$ , and the expression is undefined. It turns out in this case the appropriate expression for the temperature difference is the “arithmetic mean temperature difference:”

$$\Delta T_{AMTD} = [(T_{h2} - T_{c2}) + (T_{h1} - T_{c1})] / 2. \quad (2.3)$$

How would you handle this as part of your computer model? You would implement this as an IF ELSE statement. If the absolute value of the difference of the two temperatures of approach were below some tolerance, the arithmetic temperature difference would be used instead of the log mean temperature difference. This would prevent the model from crashing. The example of a heat pump at the end of this chapter implements this strategy.

Sometimes the values passed to the model, even though within the bounds, do not make sense. For example, if the wire diameter of a spring were more than ½ the coil diameter, as illustrated in Fig 2.1, the spring could not physically be realized. Since it is unlikely this would represent an optimum design, the model just needs to be able to compute some sort of values without crashing. The algorithms will move away from this design as the optimization proceeds.

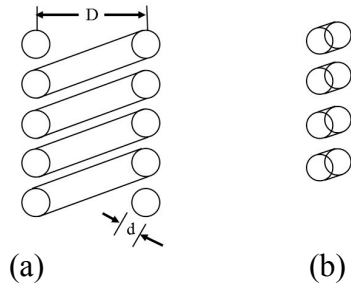

Fig. 2.1 Cross section of a spring. (a) Wire diameter,  $d$ , is reasonable relative to coil diameter,  $D$ . (b) Wire diameter is not reasonable relative to coil diameter.

One apparently obvious way to prevent something like this from happening is to include a constraint that restricts the relative sizes of the wire ( $d$ ) and coil diameters ( $D$ ), e.g.

$$2d < 0.3D \quad (2.4)$$

Often including such constraints will suffice. However, as noted, some optimization algorithms will violate constraints during a search, so this may not always work.

Finally, some models are just inherently fragile. For certain combinations of variables, the models do not converge or in some manner fail. If the model cannot easily be made more robust, then the following strategy can be used.

If a design is passed in from the optimization software for which the model cannot compute some functions, that design is intercepted at some appropriate point inside the model, and a *penalty* function is passed back in place of the actual objective (with reasonable values given to constraints). The penalty function value is high enough (assuming we are minimizing) that the algorithms will naturally move away from the point that is causing trouble.

The penalty function often is composed of the objective and a penalty proportional to the violation of the constraints:

$$P = f + \sum_{i=1}^{viol} K_i g_i \quad (2.5)$$

where  $K_i$  is a positive constant,  $g_i$  is the value of the constraint violation, and the subscript  $i$  only goes over the violated constraints.

The important point to note is that the model needs to be able to survive such designs, so the optimization can proceed.

### 2.3.2 Making Sure the Model is Adequate

Engineering models always involve assumptions and simplifications. An engineering model should be as simple as possible, but no simpler. If the model is not *adequate*, i.e., does not contain all of the necessary physics, the optimization routines will often exploit the

inadequacy in order to achieve a better optimum. Obviously such an optimum does not represent reality.

For example, in the past, students have optimized the design of a bicycle frame. The objective was to minimize weight subject to constraints on stress and column buckling. The optimized design looked like it was made of pop cans: the frame consisted of large-diameter, very thin-wall tubes. The design satisfied all the given constraints.

The problem, however, was that the model was not adequate, in that it did not consider local buckling (the type of buckling which occurs when a pop can is crushed). For the design to be realistic, it needed to include local buckling.

Models should also be checked to insure that the optimum represents a realistic design. For example, we may use a lumped mass model of a dynamic system. At the optimum, we may want to use a more sophisticated model to confirm the lumped mass model is adequate.

### 2.3.3 Testing the Model Thoroughly

The previous two sections highlight the need for a model to be tested thoroughly, especially when used in an optimization loop. The model should first be tested at several points for which solutions are known. The model should then be exercised and pushed more to its limits to see where possible problems might lie.

### 2.3.4 Reducing Numerical Noise

Many engineering models are *noisy*. Noise refers to a lack of significant figures in the function values. Noise often results when approximation techniques or numerical methods are used to obtain a solution. For example, the accuracy of finite element methods depends on the goodness of the underlying mesh. Models that involve finite difference methods, numerical integration, or solution of sets of nonlinear equations all contain noise to some degree. It is important that you recognize that noise may exist. Noise can cause a number of problems, *but the most serious is that it may introduce errors into numerical derivatives*. A discussion of the effect of noise and error on derivatives is given in Chapter 4.

Sometimes you can reduce the effect of noise by tightening convergence tolerances of numerical methods.

## 2.4 Proper Scaling of the Model Variables and Functions

Optimization algorithms perform better when functions and variables have been scaled to all be on the same order of magnitude. One scheme for scaling uses the upper and lower bounds on variables to scale them to be between  $-1$  and  $+1$ , using the equations,

$$(x_i)_{scaled} = \frac{(x_i)_{unscaled} - c_{1i}}{c_{2i}}$$
$$\text{where } c_{1i} = \frac{(x_i)_{max} + (x_i)_{min}}{2} \text{ and } c_{2i} = \frac{(x_i)_{max} - (x_i)_{min}}{2} \quad (2.6)$$

In using this approach, you should pick bounds which are as tight as possible. If during an optimization a lower or upper bound is reached (and it was set somewhat arbitrarily), it can always be relaxed.

Likewise, a function can be scaled to be on the order of 1 using either a typical value, if an objective, or the allowable value,  $b_i$ , if a constraint,

$$(f_i)_{scaled} = \frac{(f_i)_{unscaled}}{b_i} \quad (2.7)$$

Since a derivative involves both functions and variables, it is affected by the scaling of both. If the scaling of (2.6) and (2.7) is used, the relationship is,

$$\left(\frac{\partial f_i}{\partial x_j}\right)_{scaled} = \left(\frac{\partial f_i}{\partial x_j}\right)_{unscaled} \frac{[(x_j)_{max} - (x_j)_{min}]}{2 \cdot (b_i)} \quad (2.8)$$

Scaling is important. Improperly scaled functions or variables may cause premature algorithm termination or failure to make progress. When the problem is properly scaled, the derivatives should all be roughly the same order of magnitude.

As an example, the un-scaled derivatives for the two-bar truss are given in Fig. 2.2.

	weight	stress	stress-buckling	deflection
height	0.5997942	-0.5501704	5.633651	-0.001100304
diameter	11.99578	-11.00350	-134.3756	-0.02200700
width	0.2998971	0.2750989	3.367010	0.001650621
thickness	239.9157	-220.0443	-226.2133	-0.4400886

Fig. 2.2. Un-scaled derivatives for the two-bar truss

Note that the un-scaled derivatives differ by about five orders of magnitude. This could affect the termination or speed of the algorithms, because some variables dominate others.

Once we scale the variables and functions, the derivatives are much closer in value. An example of scaled derivatives for the truss are shown in Fig. 2.3,

	weight	stress	stress-buckling	deflection
height	0,1999314	-0,1100341	1,126730	-0,05501520
diameter	0,3998595	-0,2200700	-2,687512	-0,1100350
width	0,1999314	0,1100396	1,346804	0,1650621
thickness	1,799368	-0,9901994	-1,017960	-0,4950997

Fig. 2.3. Scaled derivatives for the two-bar truss.

We see that the gradients are now all the same order of magnitude. This will facilitate the optimization search.

Scaling of functions, variables and derivatives does not change the solution to the optimization problem. Rather what we are doing is picking a different set of units (obviously we could calculate weight in grams or pounds and it shouldn't make a difference to the solution). In effect we have chosen units such that all functions, variables and derivatives have similar magnitudes. More information about scaling is discussed in Gill, Murray and Wright [2].

## 2.5 Formulating Objectives

### 2.5.1 Single Objective Problems

Most optimization problems, by convention, have one objective. This is at least partially because the mathematics of optimization were developed for single objective problems. Multiple objectives are treated briefly in this chapter and more extensively in Chap. 6.

Usually in optimization the selection of the objective will be obvious: we wish to minimize pressure drop or maximize heat transfer, etc. However, sometimes we end up with a surrogate objective because we can't quantify or easily compute the real objective.

For example, it is common in structures to minimize weight, with the assumption the minimum weight structure will also have the minimum cost since we are using less material. This may not always be true, however. In particular, if minimum weight is achieved by having every member be a different size, the optimum could be very expensive to fabricate. Thus the designer should always keep in mind the assumptions and limitations associated with the objective of the optimization problem.

Often in design problems there are other objectives or constraints for the problem which we can't include. For example, aesthetics or comfort are objectives which are often difficult to quantify. For some products, it might also be difficult to estimate cost as a function of the design variables.

These other objectives or constraints must be factored in at some point in the design process. The presence of these other considerations means that the optimization problem only partially captures the scope of the design problem. Thus the results of an optimization should be considered as one piece of a larger puzzle. Usually a designer will explore the design space and develop a spectrum of designs which can be considered as final decisions are made.

### 2.5.2 Special Objectives: Error Functions

Consider the four bar linkage shown in the Fig. 2.5a below as discussed by Fox [1]. We would like the linkage to follow a particular path as given by the solid in line in Fig. 2.5b. The actual output of a particular design is given by the dashed line. In this case we would like to design a linkage such that the generated output and the desired output match as closely as possible.

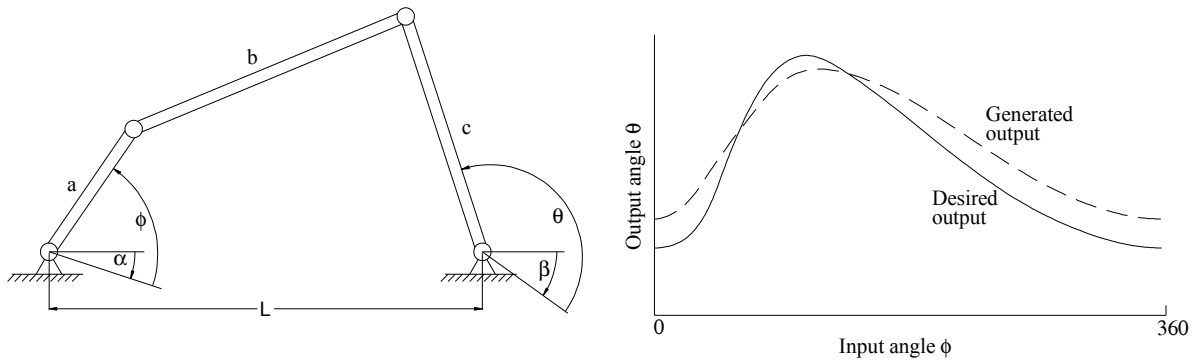

Fig 2.5 a) A four bar linkage. After Fox [1].

b) Desired output vs. generated output

A question arises as to what the objective function should be. We need an objective which provides a measure of the error between the desired and actual output. The optimization algorithms would then try to reduce this error as much as possible. One such error function would be,

$$Error = \sum_{\phi=0}^{360} (\theta_{actual} - \theta_{desired})^2 \quad (2.9)$$

Squaring the difference in the above expression insures that the error accumulates whether positive or negative. Other error functions are also possible, such as an actual integration of the area between the two curves. If it is more important that the error be small for some parts of the range, we can add a weighting function,

$$Error = \sum_{\phi=0}^{360} w(\phi)(\theta_{actual} - \theta_{desired})^2 \quad (2.10)$$

Where  $w(\phi)$  has higher values for the more important parts of the range. (Often weighting functions are constructed so the weights sum to 1.)

Error functions such as this are relatively common in engineering optimization. You should pay particular attention to scaling of an error function, as it is possible for a function such as this to vary over several orders of magnitude from the starting point to the optimum. Sometimes scaling which is appropriate at the start needs to be revised closer to the optimum.

### 2.5.3 Special Objectives: Economic Objective Functions

One type of optimization looks at the trade-off between capital costs made now, and savings resulting from the capital costs which occur later. For example, we could purchase a heat pump now (the capital cost) in order to save energy for a number of years. Typically the more expensive the heat pump is, the more energy we will save. We are interested in determining the optimal size of the heat pump that results in the best economic results.

To do this properly we must take into account the time value of money. The fact that money earns interest means that one dollar today is worth more than one dollar tomorrow. If the interest rate is 5%, compounded annually, \$1.00 today is the same as \$1.05 in one year. If expenses and/or savings are made at different times, we must convert them to the same time to make a proper comparison. This is the subject of engineering economics, and we will only briefly treat the subject here.

One approach to examining the economics of projects is called *net present value (NPV)*. For this approach, all economic transactions are converted to equivalent values in the present. In general, outflows (expenses) are considered negative; inflows (savings or income) are considered positive. There are two formulas which will be useful to us.

The present value of one future payment or receipt,  $F$ , at period  $n$  with interest rate  $i$  is,

$$P = \frac{F_n}{(1+i)^n} \quad (2.11)$$

This equation allows us to convert any future value to the present. This might not be very convenient, however, if we have many future values to convert, particularly if we have a series of uniform payments. The present value of a series of uniform amounts,  $A$ , where the first payment is made at the end of the first period is given by,

$$P = A \frac{(1+i)^n - 1}{i(1+i)^n} \quad (2.12)$$

#### 2.5.3.1 Example: Net Present Value of Heat Pump

Suppose you can buy a heat pump for \$50,000. The pump is estimated to save \$12,000 per year for the five-year life of the pump. An interest rate of 10% is assumed. Is the heat pump a good investment?

A time line showing the money flow rates is given below (size of arrows not to scale).



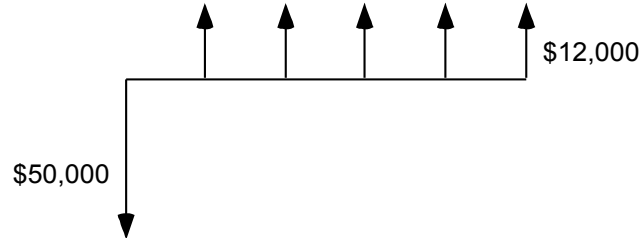

Fig. 2.6. Money flow rates for heat pump.

The initial expense of the pump, \$50,000, is already in the present, so this does not need to be changed. It will be considered negative, however, since it is money paid out.

The value of the savings, when brought to the present, is given by

$$P = A \frac{(1+i)^n - 1}{i(1+i)^n} = 12,000 \frac{(1+0.10)^5 - 1}{0.10 * (1+0.10)^5} = \$45,489$$

The net present value is given by,

$$NPV = -\$50,000 + \$45,489 = -\$4510$$

Since the Net Present Value is negative, this is not a good investment. This result might be a little surprising, since without taking into account the time value of money, the total savings is  $5 * \$12,000 = \$60,000$ . However, at 10% interest, the value of the savings, when brought back to the present, does not equal the value of the \$50,000 investment. This means we would be better off investing the \$50,000 at 10% than using it to buy the heat pump. Note that this example assumes the first \$12,000 of savings is realized at the end of the first period, as shown by the timeline for the example.

When used in optimization, we usually would like to maximize net present value. In terms of the example, as we change the size of the heat pump (by changing, for example, the size of the heat exchangers and compressor), we change the initial cost and the annual savings.

Question: How would the example change if the heat pump had some salvage value at the end of the five years?

## 2.6 Formulating Constraints

### 2.6.1 Inequality and Equality Constraints

Almost all engineering problems are constrained. Constraints can be either inequality constraints ( $\leq b_i$  or  $\geq b_i$ ) or equality constraints ( $= b_i$ ). The feasible region for inequality constraints represents the entire area on the feasible side of the allowable value; for equality constraints, the feasible region is only where the constraint is equal to the allowable value.

Because equality constraints are so restrictive, they should be employed carefully (an exception would be linear constraints, which are easily handled). If the constraint is simple, it

can sometimes be eliminated by explicitly solving for a variable. This eliminates a design variable and the equality constraint from the problem.

### **2.6.2 Constraints Where the Allowable Value is a Function**

It is very common to have constraints of the form:

$$\text{Stress} \leq \text{Buckling Stress} \quad (2.13)$$

Most optimization routines, however, cannot handle a constraint that has a function for the right hand side. This is easily remedied by rewriting the function to be,

$$\text{Stress} - \text{Buckling Stress} \leq 0 \quad (2.14)$$

### **2.6.3 Constraint with Two Allowable Values**

Constraints sometimes also have upper and lower allowable values:

$$4 \leq \text{DiameterRatio} \leq 16 \quad (2.15)$$

We can break this into two constraints:

$$\begin{aligned} \text{DiameterRatio} &\leq 16 \\ \text{DiameterRatio} &\geq 4 \quad (\text{or } -\text{DiameterRatio} \leq -4) \end{aligned}$$

### **2.6.4 Taking the Maximum of a Group of Functions**

Sometimes we would like to reduce the size of a problem by combining several constraints together. For example, in a finite element model, it may be expensive to place a stress constraint on every element. One possibility is to group a block of elements together and take the maximum stress over the group.

However, the Max function has a drawback in that it is not differentiable when the max value changes from one analysis function to another. Usually, however, the optimization algorithms can successfully skip over this discontinuity.

### **2.6.5 Parametric Constraints**

Suppose we have a truss where the load acts within some envelope, as shown in Fig. 2.10 below,

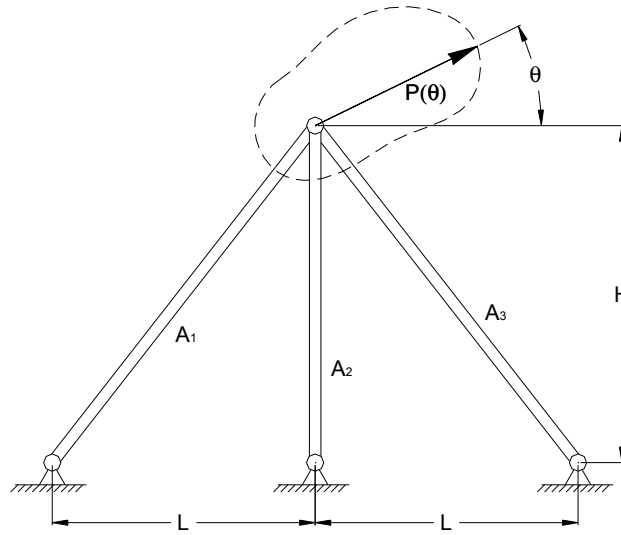

Fig. 2.10. A three-bar truss with a parametric load, after Fox [1].

The load can act in any direction, and the magnitude is a function of  $\theta$ . We could write the constraint as,

$$\text{Stress}(\theta) < S_y \quad 0 \leq \theta \leq 2\pi \quad (2.16)$$

Fox refers to this as a *parametric constraint*. How would we evaluate this type of constraint?

As you may have guessed, we would use a loop inside our analysis routine. We would loop through values of theta and keep track of the highest value of stress. This is the value which would be sent to the optimizer. Pseudo-code for the loop would be something like (where we assume theta is in degrees and is incremented by two degrees each time through the loop),

```
maxstress = 0.0;
For (theta = 0; theta <= 360; theta += 2.0;) {
    stress = (calculate stress);
    If (stress >> maxstress ) maxstress = stress;
}
```

## 2.7 Interpreting Graphics

This section may seem an odd subject for a chapter on modeling—interpreting graphs of the design space. However graphs of the design space can tell us a lot about our model. If we can afford the computation, it can be very helpful to look at graphs of design space.

We will discuss two basic types of plots: sensitivity plots (where functions are plotted with respect to one variable) and contour plots (where functions are plotted with respect to two variables). To create a sensitivity plot, one variable is changed at equal intervals, according to the number of points specified, and the analysis routine is called at each point. If ten points are used, the analysis routine is called ten times.

To create a contour plot, two variables are changed at equal intervals (creating a mesh in the space) and then graphed. If ten points are used for each variable, the analysis routine is called 100 times.

Some points to remember:

- Use graphs to help you verify your model. Do the plots make sense?
- Graphs can provide additional evidence that you have a global optimum. If the contours and constraint boundaries are smooth and relatively linear, then there are probably not a lot of local optima. Remember, though, you are usually only looking at a slice of design space.
- When you generate a contour plot, remember that all variables except the two being changed are held constant at their current values. Thus if you wish to see what the design space looks like around the optimum, you must be at an optimum.
- Graphs can often show why the algorithms may be having trouble, i.e. they can show that the design space is highly nonlinear, that the feasible region is disjoint, that functions are not smooth, etc.
- Graphs are interpolated from the underlying mesh. Make sure the mesh is adequate. The mesh must be fine enough to capture the features of the space. Make sure that the ranges for the variables are such that the designs are meaningful. In some cases, if the ranges are not appropriate, you may generate designs that are undefined.

In the figures below we show some examples of contour plots which can help us gain insight into an analysis model.

The first plot, shown in Fig. 2.12 below, illustrates several features of interest. We note that that we have two optimums in the middle of the graph. We also have a step in the middle of the graph where the contours are steep—this would likely mean the algorithms would “fall” down the step and find the second optimum. Also, in the upper left corner the contours are very close together. The “diamond” shapes along the right side are probably not real—these can occur when the underlying mesh is not fine enough.

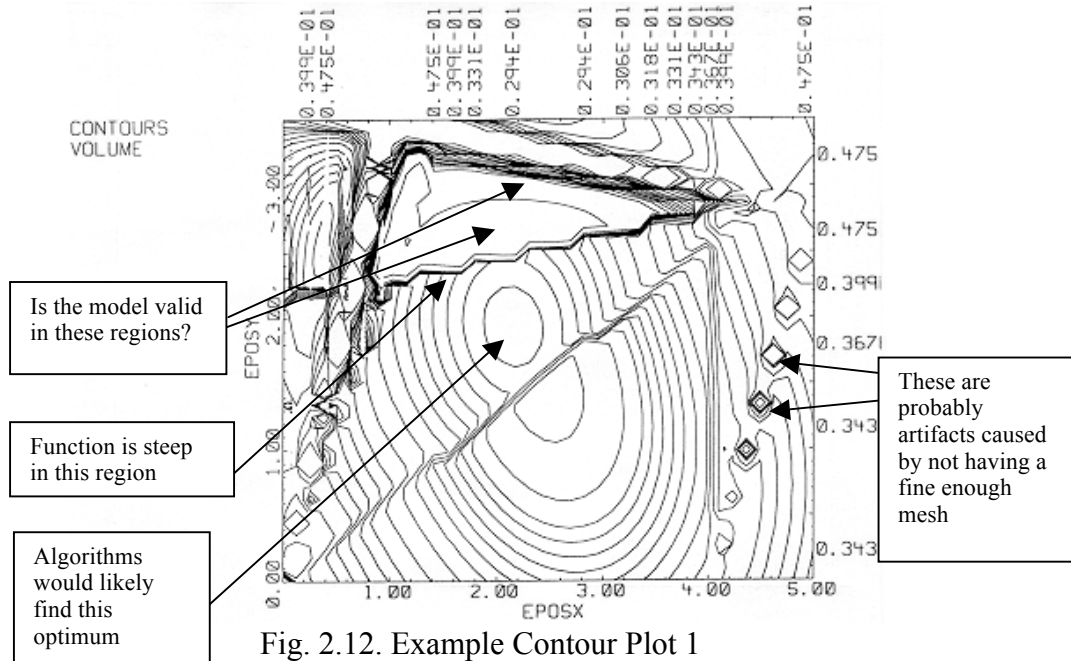

Our next example is shown in Fig. 2.13. In this example, which represents the design space for a spring, we have a lot of constraint boundaries. The feasible side of the constraint is denoted by a triangular marker. As we examine constraint boundaries, we see that the feasible region appears to be a triangular area, as shown. In the lower right hand corner, however, we have an area of suspicious looking constraint boundaries (constraint 2), which, if valid, would mean no feasible region exists. When we consider the values of variables in this area, however, we understand that this boundary is artifact of the model. In this part of the plot, the wire diameter is greater than the coil diameter. Since this is impossible with a real spring, we know this boundary is false and can be ignored.

Explore 2D Analysis Jan 15 10:34

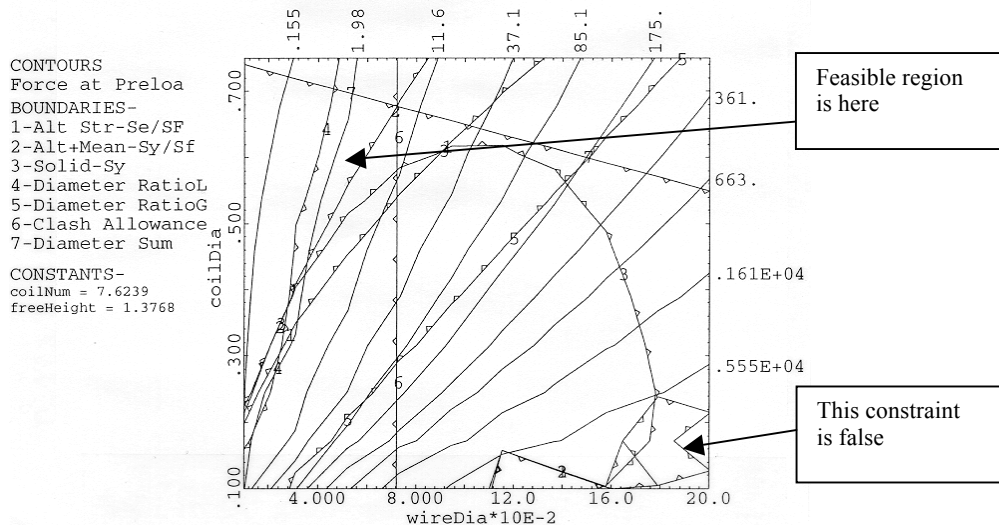

Our third and final example is given in Fig. 2.14. This is a sensitivity plot. The functions plotted as 2,3,4,5 look reasonable. Function 1, however, exhibits some noise. We may wish to see if we can eliminate this noise if possible.

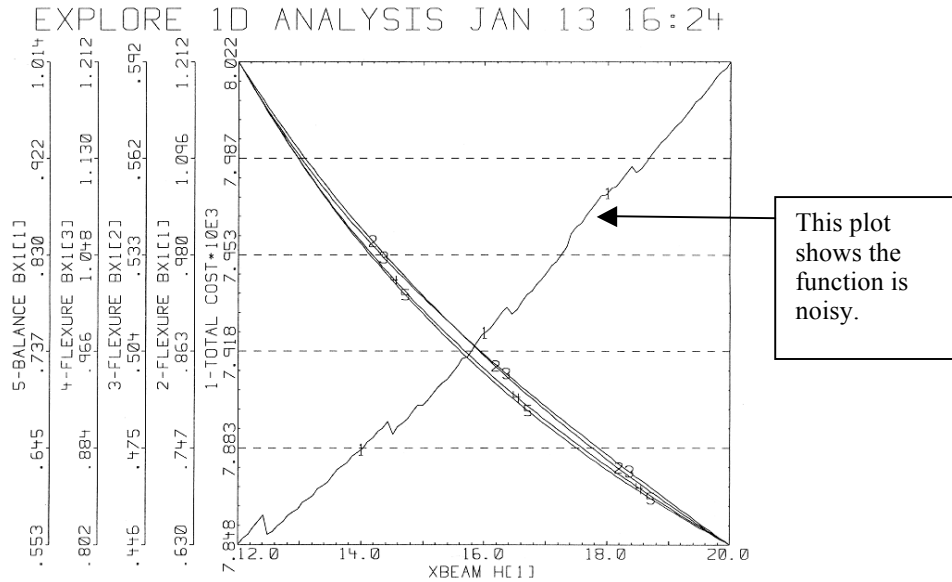

Fig. 2.14. Example Sensitivity Plot

## 2.8 Modeling and Optimization Example: Optimization of a Heat Pump

### 2.8.1 Problem Description

To save energy, the installation of a heat pump is proposed as shown in Fig. 2.15. The heat pump recovers heat from exhaust air and transfers it to incoming outdoor air. The building is electrically heated, so that if the heat pump does not bring the temperature of the incoming air up to 35°C, electric-resistance heat is used to supplement the heat pump. This problem is a modified version taken from Stoeker[3].

Determine the size of compressor, condenser, and evaporator that provides a minimum total cost (capital costs and operating costs). The temperatures of approach in the evaporator and condenser should not be less than four degrees C.

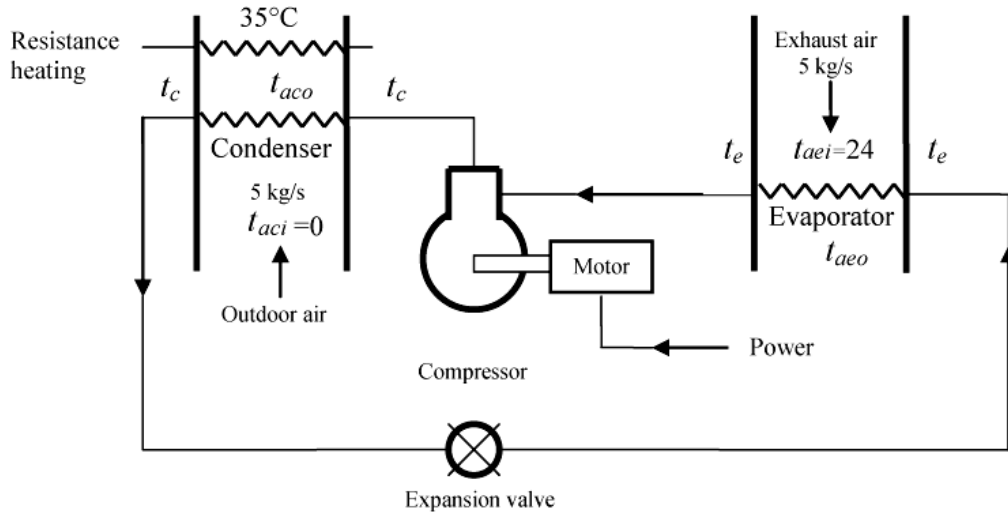

Fig. 2.15. Schematic of Heat Pump, after Stoecker [3].

**Data**

U Values of condenser and evaporator coils,  $25 \text{ W} / (\text{m}^2 \cdot \text{K})$  based on air-side area.

Cost of coils, \$100 per square meter of air-side area

Compressor cost, including motor, \$220 per motor kilowatt

Power cost, 6 cents per kilowatt-hour

Interest rate, 10 percent

Economic life, 10 years

Number of hours of operation per year, 4000

Average outdoor temperature during the 4000 h,  $0^\circ\text{C}$

Air flow rate through both coils,  $5 \text{ kg/s}$

Temperatures of approach in the exchangers should be at least  $4^\circ\text{C}$ .

The performance characteristics of the compressor can be expressed as a Coefficient of Performance (COP), where

$$\text{COP} = \frac{\text{refrigeration rate, kW}}{\text{electric power to compressor motor, kW}}$$

(Refrigeration rate is the heat absorbed at the evaporator.) The COP is a function of the evaporating and condensing temperatures,  $t_e^\circ\text{C}$ , and  $t_c^\circ\text{C}$ , and can be represented by

$$\text{COP} = 7.24 + 0.352t_e - 0.096t_c - 0.0055t_et_c \quad (2.17)$$

**2.8.2 Initial Problem Discussion**

This problem involves determining the optimal trade-off between first costs and operating costs. If we are willing to put in a more expensive heat pump (larger heat exchangers and compressor) we can recover more heat and energy costs drop. Conversely, we can reduce

initial costs by installing a smaller heat pump (or no heat pump at all) but energy costs are then higher. This is a relatively common situation with engineering systems.

We have obviously made a number of simplifications to this problem. For example, we are not considering any benefit which might accrue from running the heat pump as an air conditioner during the summer. We are also using a relatively simple model for the condenser, evaporator and compressor. The optimization is conducted on the basis of a constant outdoor air temperature of 0°C.

Although not considered here, during actual operation the COP of the system would vary with the outdoor air temperature. A more complex analysis would analyze the savings assuming different outdoor air temperatures for certain times of the year, month or day.

From consideration of the problem we define the following:

$Q_c$  = heat transfer, condenser

$Q_e$  = heat transfer, evaporator

$Q_r$  = heat transfer, resistance heater

$A_c$  = area of condenser

$A_e$  = area of evaporator

$W$  = work input to compressor

$\dot{m}$  = air mass flow rate (5 kg / s)

$C_p$  = specific heat, air (1.0 kJ / kg)

$t_e$  = working fluid temperature, evaporator

$t_c$  = working fluid temperature, condenser

$t_{aci}$  = inlet air temperature, condenser (0° C)

$t_{aco}$  = outlet air temperature, condenser

$t_{aei}$  = inlet air temperature, evaporator (24° C)

$t_{aeo}$  = outlet air temperature, evaporator

$t_{appe}$  = temperature of approach, evaporator

$t_{appc}$  = temperature of approach, condenser

COP = coefficient of performance

$C_{hp}$  = cost of heat pump

$C_{ehp}$  = cost of electricity for heat pump

$C_{erh}$  = cost of electricity for resistance heater

$C_{total}$  = total cost

Some of these will be design variables and some will be design functions. In order to better understand these relationships, it will be helpful to write the equations for the model.



### 2.8.3 Definition of Optimization Problem

The definition of the optimization problem is not always obvious. In this case it is clear what the objective should be: to minimize overall costs (cost of heat pump and cost of energy over ten years). We also note we will have constraints on the temperature of approach in the evaporator and condenser. However, it is not clear what the design variables should be. For example, we need to determine  $t_{aco}, t_{aao}, t_e, t_c, Q_e, Q_c, A_e, A_c$  and  $W$ .

Not all of these can be design variables, however, because once some of these are set, others can be calculated from the modeling equations. Some modeling equations essentially act as equality constraints and can be used to eliminate variables (as discussed in Section 2.6.1.)

For now we will define the optimization problem as follows,

Find  $t_{aco}, t_{aao}, t_e, t_c, Q_e, Q_c, A_e, A_c$  and  $W$

To Minimize  $C_{total}$

$$\text{s.t. } \begin{aligned} t_{appe} &> 4 \\ t_{appc} &> 4 \end{aligned}$$

In the next sections, where we define the model and equation sequence, we will be able to refine this definition further.

### 2.8.4 Model Development

The following equations will apply to the heat pump model,

Equation	Explanation
$Q_c = Q_e + W$	This equation comes from an energy balance across the heat pump. During steady state operation, the heat transferred at the condenser is equal to the heat absorbed at the evaporator and the energy input to the compressor.
$Q_c = UA_c \Delta T_c$	This gives the heat transferred at the condenser in terms of the heat transfer coefficient, area and temperature difference.
$\Delta T_c$	This is the temperature difference across the condenser and is calculated as the log mean temperature difference: $\Delta T_c = \frac{\{(t_c - t_{aci}) - (t_c - t_{aco})\}}{\ln \{(t_c - t_{aci}) / (t_c - t_{aco})\}}$
$Q_c = \dot{m} C_p (t_{aco} - t_{aci})$	The heat transferred at the condenser must equal the sensible heat gain of the air across the condenser.
$Q_e = UA_e \Delta T_e$	The heat transferred at the evaporator.
$\Delta T_e$	The temperature difference across the evaporator:

	$\Delta T_e = \frac{\{(t_{aei} - t_e) - (t_{aeo} - t_e)\}}{\ln\{(t_{aei} - t_e)/(t_{aeo} - t_e)\}}$
$Q_e = \dot{m}C_p(t_{aei} - t_{aeo})$	The heat transferred at the evaporator must equal the sensible heat loss of the air across the evaporator.
$Q_r = \dot{m}C_p(35 - t_{aco})$	Heat transfer to air by resistance heater.
$COP = \frac{Q_e}{W} = f(t_e, t_c)$	Definition of coefficient of performance (note for this problem it specifies the COP in terms of “refrigeration rate,” which implies $Q_e$ instead of $Q_c$ . The actual equation for the COP is given in (2.17)
$C_{total} = C_{hp} + C_{ehp} + C_{erh}$	We must bring the energy costs for the heat pump and the resistance heater into the present by calculating their present value. Other costs are already in the present. We will use (2.12) to do this: $P = A \frac{(1+i)^n - 1}{i(1+i)^n}$
$t_{appe} = (t_{aeo} - t_e)$	Temperature of approach for the evaporator. This is the difference between the air exit temperature and the working fluid temperature.
$t_{appc} = (t_{aco} - t_c)$	Temperature of approach for the condenser.

It pays to be careful as you develop model equations. An error here can cause lots of grief downstream. One recommendation is to check the units of all equations to make sure the units are correct.

### 2.8.5 Equation Sequence

In this step we will determine the order in which equations will be calculated. This will help us determine the set of design variables. It turns out, as we lay out the model equations, we find we only need three design variables. Once these three are set, all the others can be calculated.

We will guess that we have design variables:  $t_{ace}, t_e, t_c$  (this guess is not obvious—it sometimes takes some iterations of this step to decide what the most convenient set of variables will be).

Get values of design variables from optimizer: $t_{ace}, t_e, t_c$ ↓	The optimization code will set the values of these variables.
Compute $COP = f(t_e, t_c)$ ↓	From (2.17)

$Q_e = \dot{m}C_p(t_{aei} - t_{aeo})$ $= (5\text{kg/s})(1.00\text{kJ/kg}^\circ\text{C})(24 - t_{aeo})$ <p style="text-align: center;">↓</p>	Calculate heat transferred to air from evaporator
$W = Q_e / \text{COP}$ <p style="text-align: center;">↓</p>	Knowing $Q_e$ and COP the Work can be calculated
$Q_c = Q_e + W$ <p style="text-align: center;">↓</p>	Heat at condenser
$t_{aco} = \frac{Q_c}{\dot{m}C_p} + t_{aci}$ <p style="text-align: center;">↓</p>	Outlet air temperature of condenser
$A_c = Q_c / U\Delta T_c$ <p style="text-align: center;">↓</p>	Area of condenser
$A_e = Q_e / U\Delta T_e$ <p style="text-align: center;">↓</p>	Area of evaporator
$C_{hp} = A_e * 100 + A_c * 100 + W * 220$ <p style="text-align: center;">↓</p>	Cost of heat pump
$C_{ehp} = W * 0.06 * 4000 * \frac{(1+i)^n - 1}{i(1+i)^n}$ <p style="text-align: center;">↓</p>	Present worth of energy cost to run heat pump
$C_{erh} = \dot{m}C_p(35 - t_{aco}) * 0.06 * 4000 * \frac{(1+i)^n - 1}{i(1+i)^n}$ <p style="text-align: center;">↓</p>	Present worth of energy cost to run resistance heater
$C_{total} = C_{hp} + C_{ehp} + C_{erh}$ <p style="text-align: center;">↓</p>	Find total cost
$t_{appe} = (t_{aeo} - t_e)$ $t_{appc} = (t_{aco} - t_c)$	Find temperatures of approach

### 2.8.6 Model Coding

We are now ready to code the model. Although the code below is for a software package called OptdesX, similar coding would need to be done to connect with any optimizer. In the routine, calls to `avdsca` retrieve analysis variable values from the optimizer, and calls to `afdsca` send values back to the optimizer. Note that even though we will only have a few

design functions, we send a lot of function values back so we can verify the model is working properly.

```
#include "supportC.h"
#include <math.h>

void anafunC(void)
{
    /* variables and functions */
    double taei, taci, taco, tao, te, tc, Ae, Ac, U, W, Qc, Qe;
    double mdot, cp, delte, deltc, Costelec, Costpump, Costtot;
    double Costresist, COP, appte, apptc, appte2, apptc2;

    /* get AV values from OptdesX (Variable names 16 chars max) */
    avdscaC( &taeo, "evap air temp out" );
    avdscaC( &te, "temp evaporator" );
    avdscaC( &tc, "temp condenser" );

    U = 0.025;
    mdot = 5.;
    cp = 1.00;
    taci = 0.;
    taei = 24.;

    COP = 7.24 + 0.352*te - 0.096*tc - 0.0055*te*tc;

    Qe = mdot*cp*(taei - tao);
    W = Qe/COP;
    Qc = Qe + W;
    taco = Qc/(mdot*cp) + taci;

    if (fabs ((taei - te) - (taeo - te)) > 0.0001) {
        delte = ((taei - te)-(taeo - te))/log((taei - te)/(taeo - te));
    }
    else {
        delte = ((taei - te)+(taeo - te))/2.;
    }
    if (fabs ((tc - taco) - (tc - taci)) > 0.0001) {
        deltc = ((tc - taco)-(tc - taci))/log((tc - taco)/(tc - taci));
    }
    else {
        deltc = ((tc - taco)+(tc - taci))/2.;
    }

    Ac = Qc/(U*deltc);
    Ae = Qe/(U*delte);

    Costelec = W*6.144*0.06*4000.;
    Costpump = Ae*100. + Ac*100. + W*220.;
    Costresist = 0.;

    if (taco < 35.) {
        Costresist = mdot*cp*(35 - taco)*6.144*0.06*4000.;
    }
    Costtot = Costresist + Costelec + Costpump;
}
```

```

appte = tao - te;
apptc = tc - taco;
appte2 = taei - te;
apptc2 = tc - taci;

afdscaC( COP, "COP" );
afdscaC( Qe, "Q evaporator" );
afdscaC( Qc, "Q condenser" );
afdscaC( W, "Work" );
afdscaC( delte, "delte" );
afdscaC( deltc, "deltc" );
afdscaC( Ac, "Area condenser" );
afdscaC( Ae, "Area evaporator" );
afdscaC( Costelec, "Cost electricity" );
afdscaC( Costpump, "Cost heat pump" );
afdscaC( Costresist, "Cost resist heat" );
afdscaC( Costtot, "Cost total" );
afdscaC( apptc, "temp app cond" );
afdscaC( appte, "temp app evap" );
afdscaC( appte2, "temp app evap2" );
afdscaC( apptc2, "temp app cond2" );
}

```

### 2.8.7 Linking and Verifying the Model

After we have coded and debugged the model, we link it to the optimizer and begin verification. (In some situations we might be able to verify the model before we link to the optimizer. In such a case we would be able to execute the model separately.) Verification involves checking the model at various points to make sure it is working properly. The values of the design variables are changed to examine the corresponding function values over the design space to verify the model is working properly.

### 2.8.8 Optimizing the Model

After debugging and checking the model at various points, we are finally ready to optimize. The first step is to make sure the scaling is appropriate.

The unscaled gradients are,

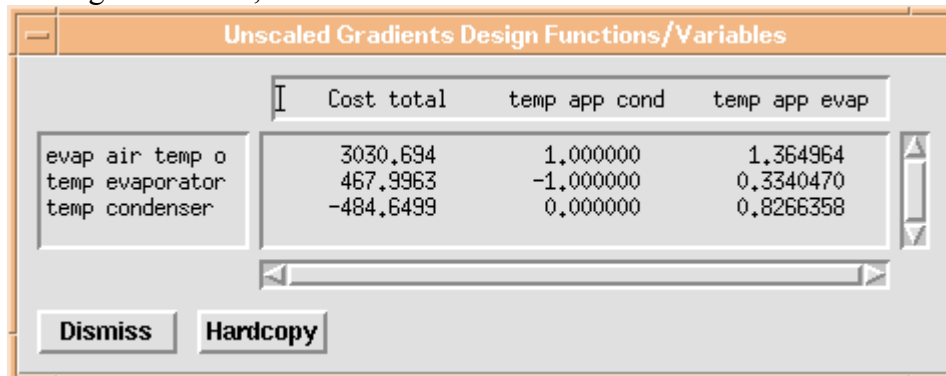

	Cost total	temp app cond	temp app evap
evap air temp o	3030.694	1.000000	1.364964
temp evaporator	467.9963	-1.000000	0.3340470
temp condenser	-484.6499	0.000000	0.8266358

Fig. 2.16 Unscaled derivatives.

We see that the derivatives vary by almost five orders of magnitude, from 0.33 to 3030. This can have the effect of slowing the search for an optimum or even causing premature

termination. If we use the scaling scheme discussed in this chapter, we see the scaled derivatives are,

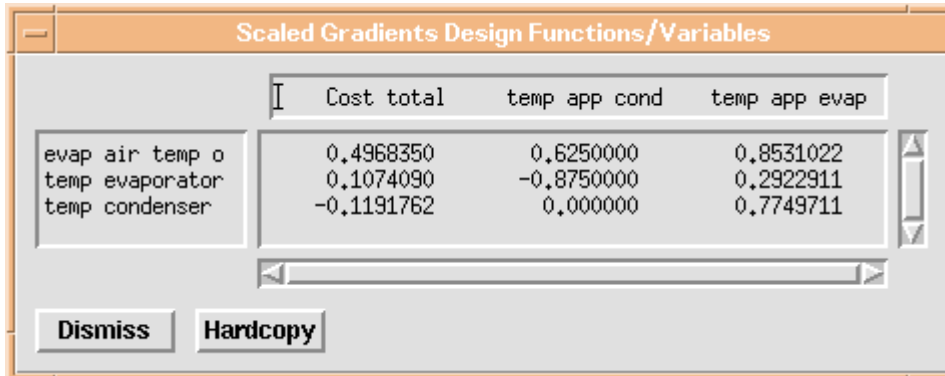

Fig. 2.17 Scaled derivatives.

The scaling is much more uniform.

The starting design is shown in Figs. 2.18 and 2.19 below:

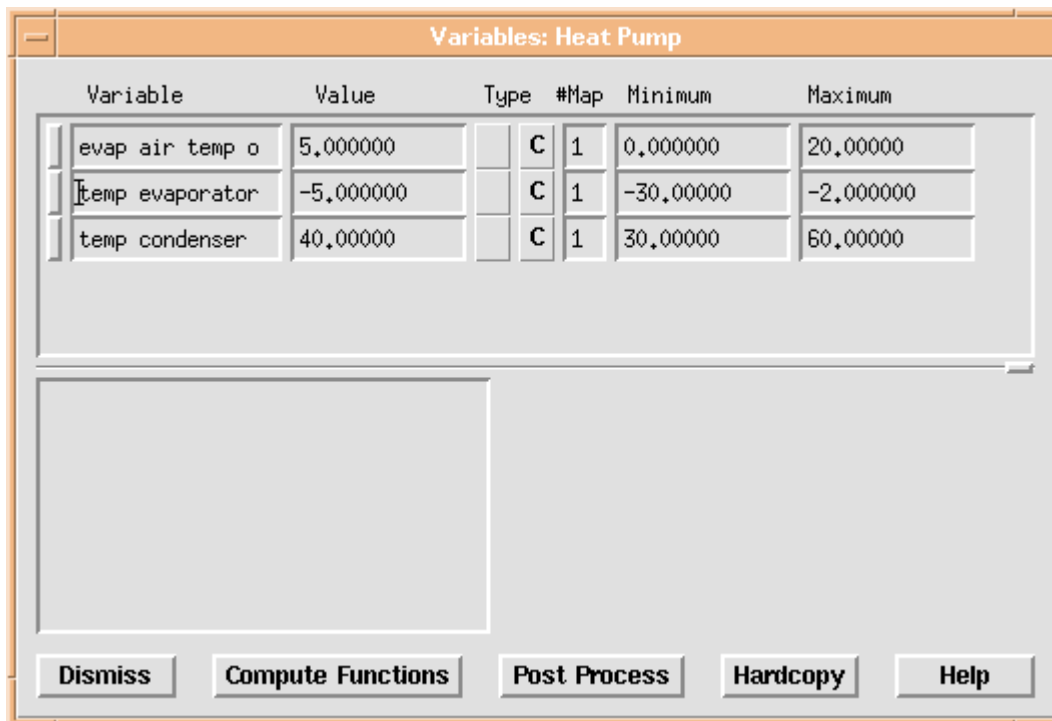

Fig. 2.18 Starting values of design variables.

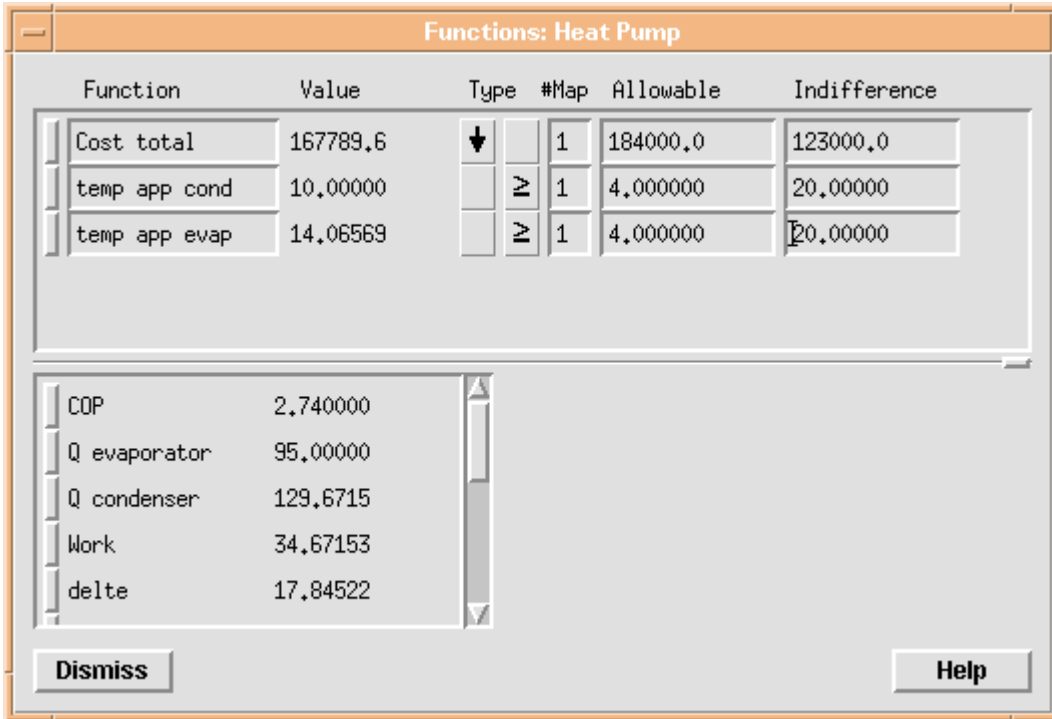

Fig. 2.19. Starting values for functions.

We are ready to optimize. We run the default algorithm GRG. The variables change to:

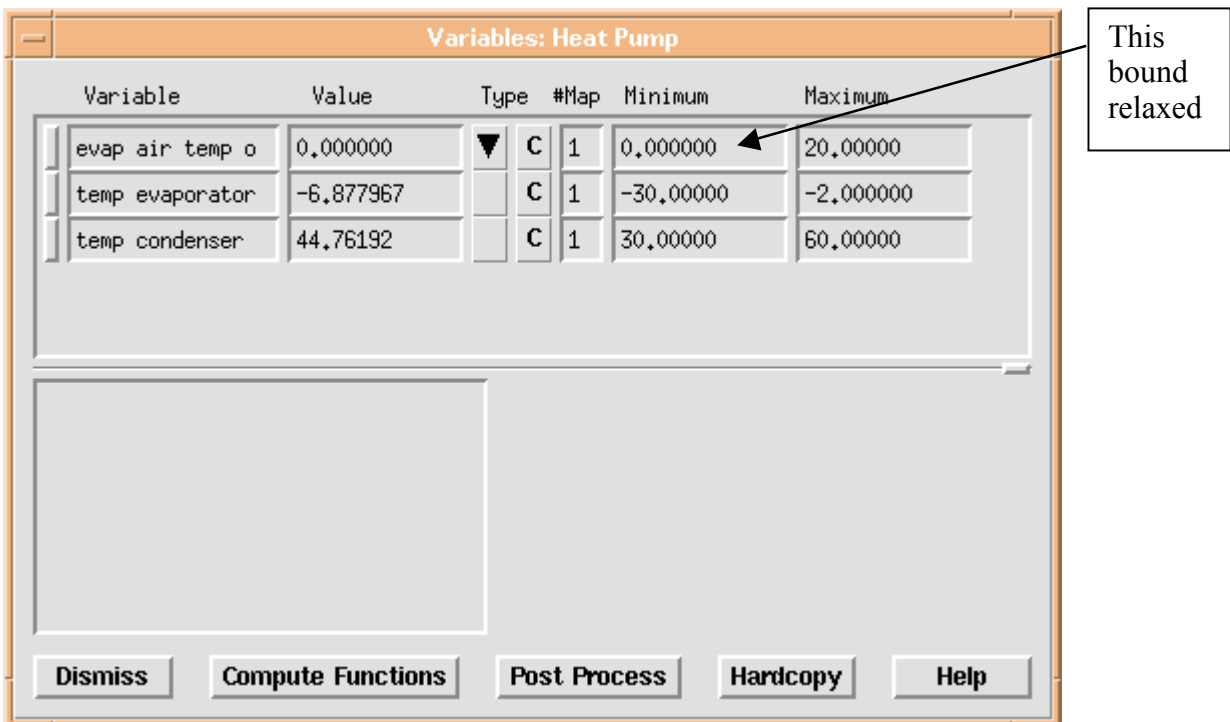

Fig. 2.20 Optimum values for variables.

We see that a design variable, evaporator air outlet temperature, has hit its lower bound of zero. We relax this bound somewhat to see if we can do better:

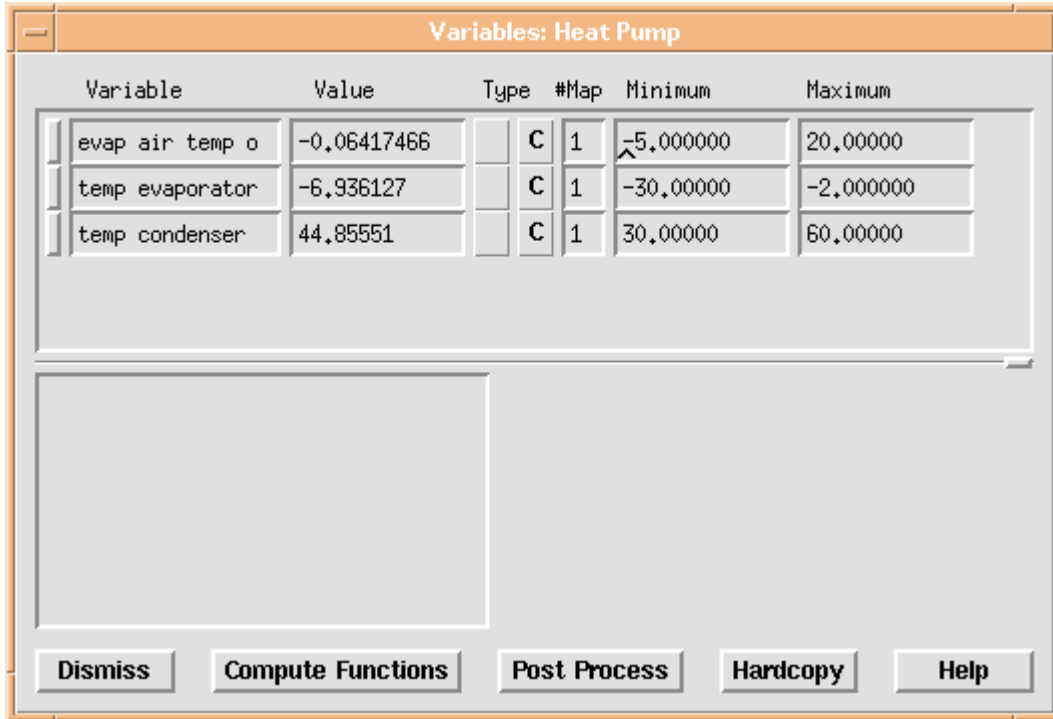

Fig. 2.21 Optimum values for variables with relaxed bound.

The functions at the optimum are given in Fig. 2.22.

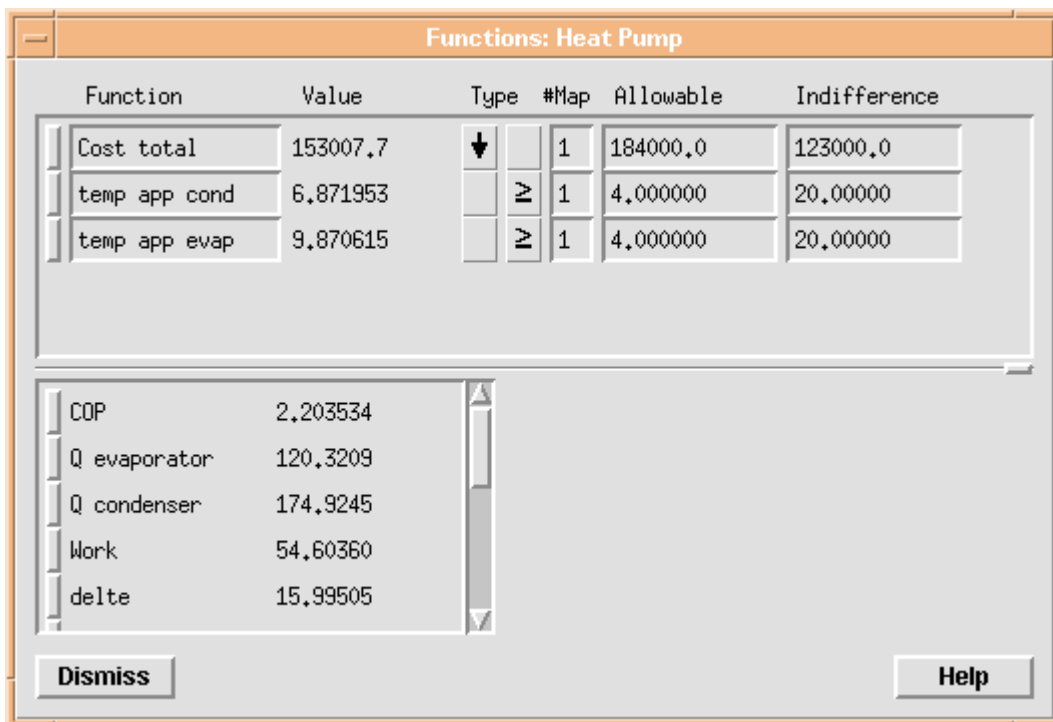

Fig. 2.22 Function values at optimum.

We see that the total cost has decreased from \$167,800 to \$153,000. Although not shown in Fig. 2.22, the cost of the resistance heating has dropped to nearly zero. Does this make sense?



We see that the COP at the optimum is 2.2, meaning for every unit of energy input to the compressor, 2.2 units of heat are delivered at the condenser. So we would expect the heat pump to be a cost effective means of delivering heat. We might continue to explore this solution to make sure we understand it.

A contour of the space around the optimum is given in Fig 2.23. We see that for this problem the solution is a relatively shallow unconstrained optimum.

Explore 2D Analysis Dec 16 11:29

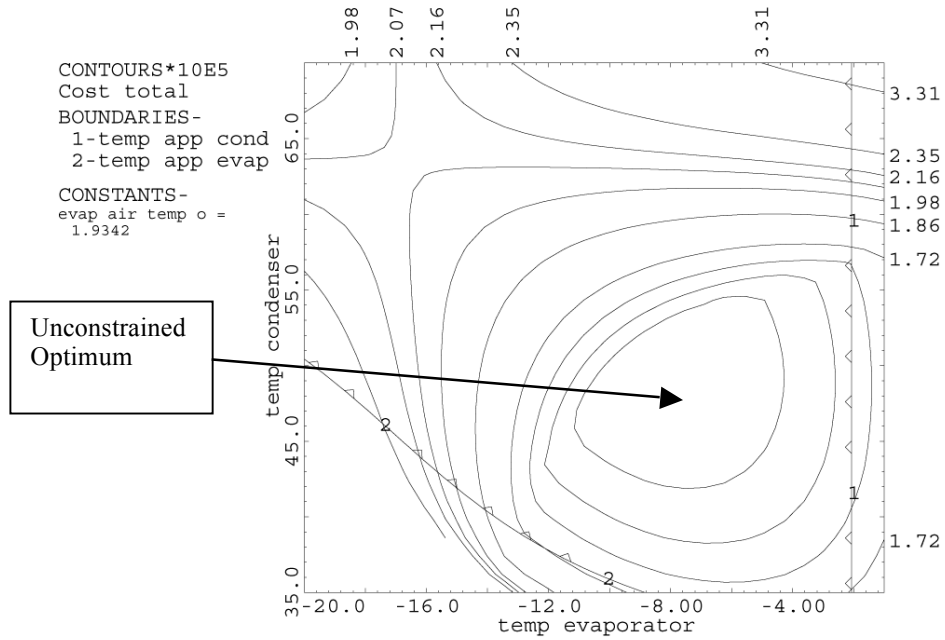

Fig 2.23 Contour plot for the heat pump.