

Valve Design

Types of Valves

(from *Fluid Mechanics*, by F. White, McGraw-Hill, 1999)

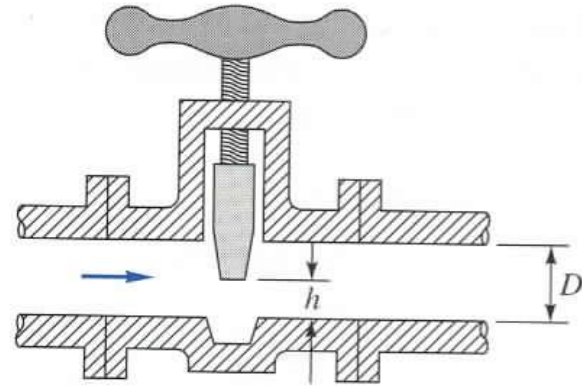

(a) Gate valve

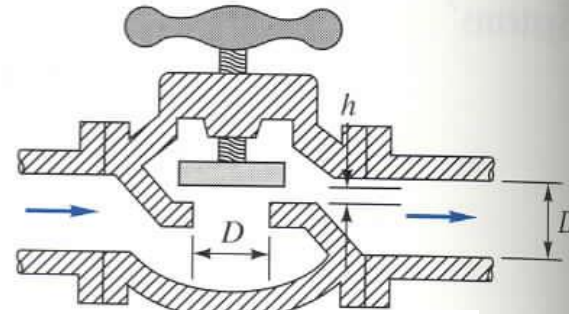

(b) Globe valve

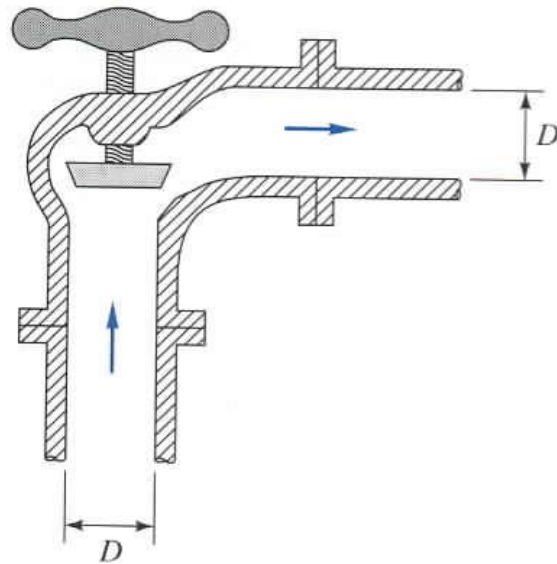

(c) Angle valve

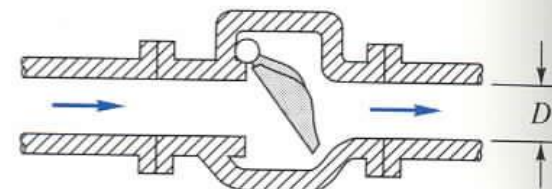

(d) Swing-check valve

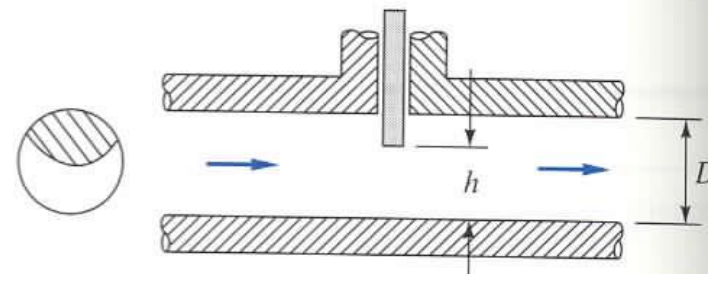

(e) Disk-type gate valve

Butterfly Valve

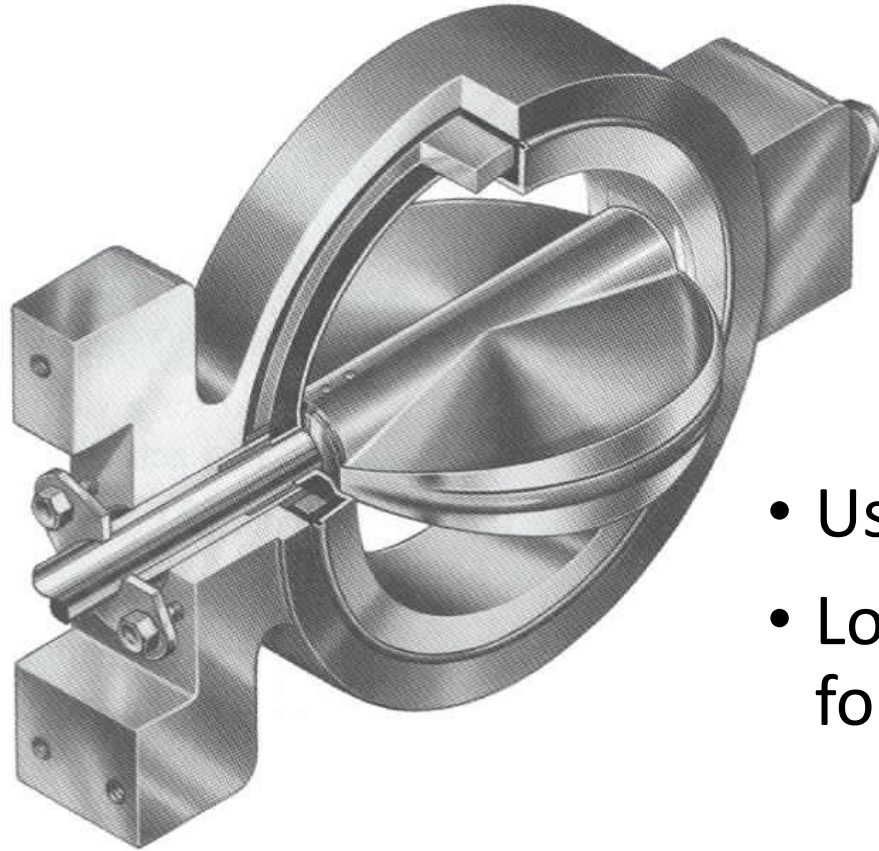

- Used mainly for on-off
- Lots of torque needed for high flow rates

(from *Chemical Process Control*, by J. B. Riggs, Ferret Publ., 2001)

Cutaway View of Globe Valve

(from *Chemical Process Control*, by J. B. Riggs, Ferret Publ., 2001)

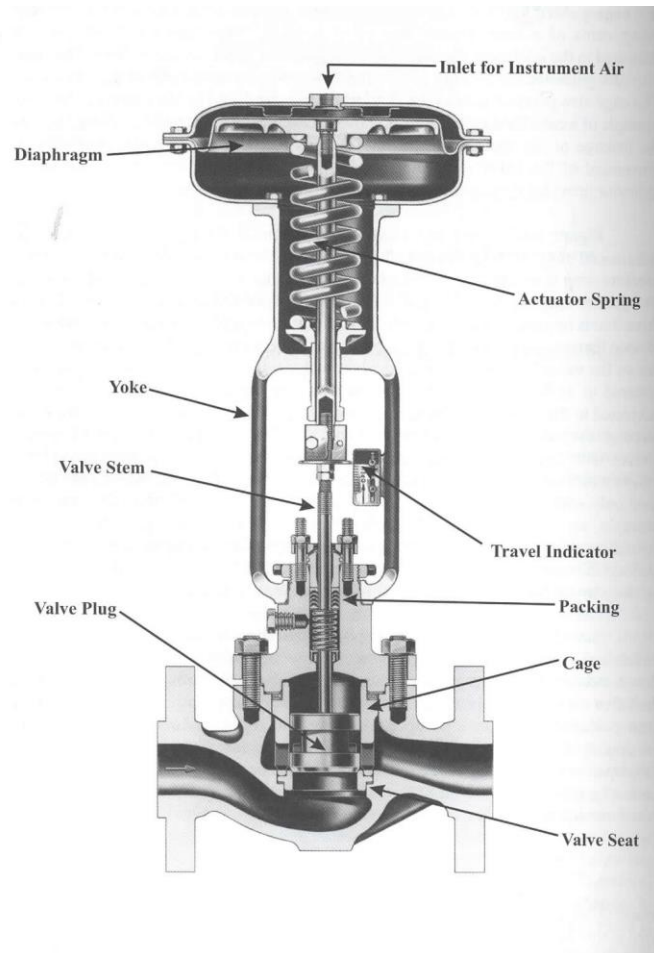

Typical globe valve



Larger View of Cage

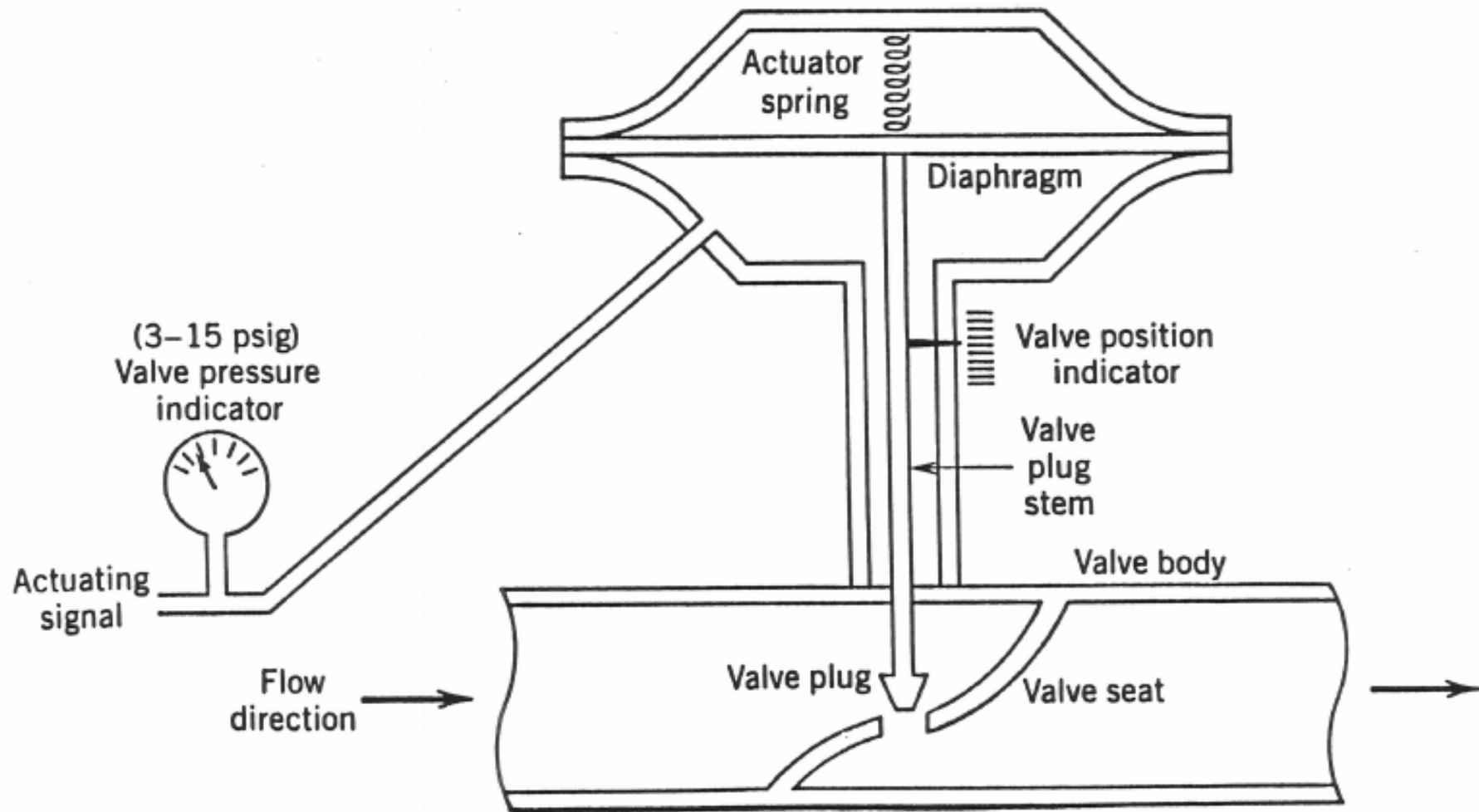
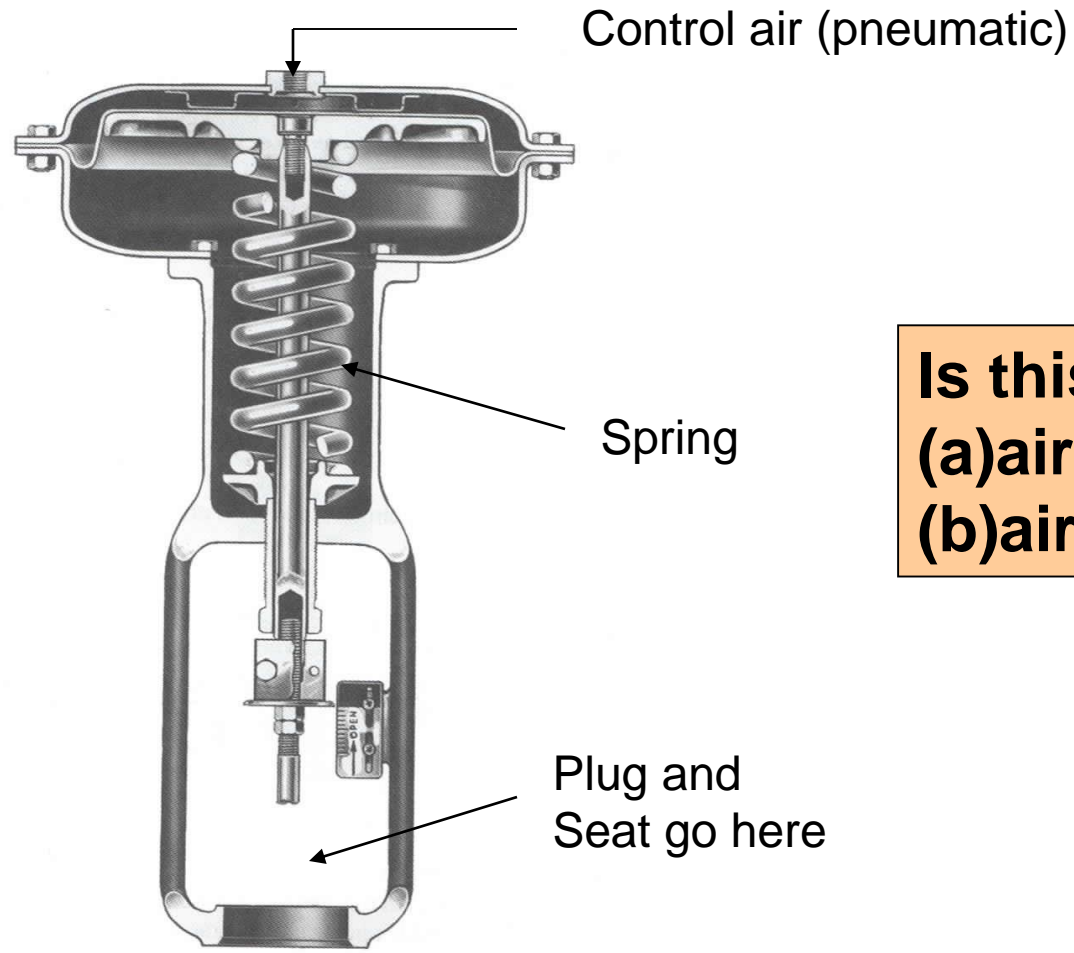

Figure 9.8. A pneumatic control valve.

Close-up of Actuator



**Is this:
(a) air to open, or
(b) air to close?**

(from *Chemical Process Control*, by J. B. Riggs, Ferret Publ., 2001)

Valve Designs

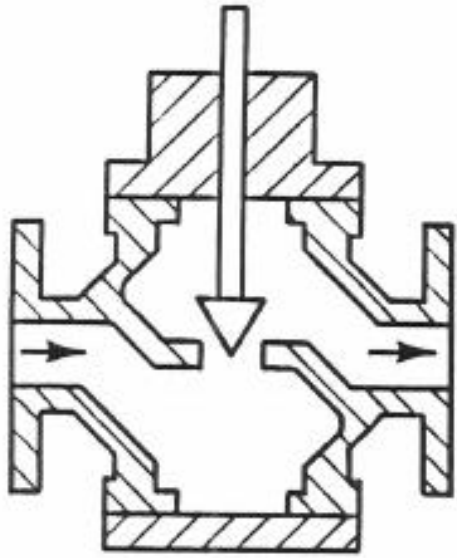

(a)

Globe

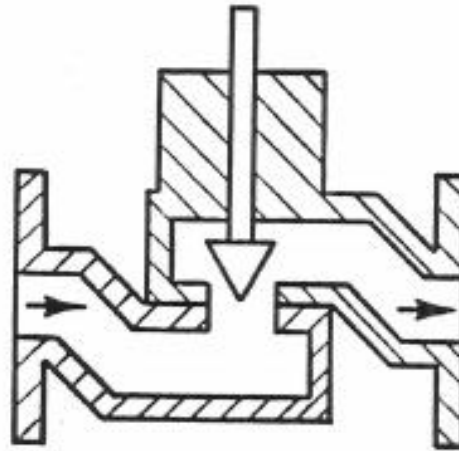

(b)

Split-Body

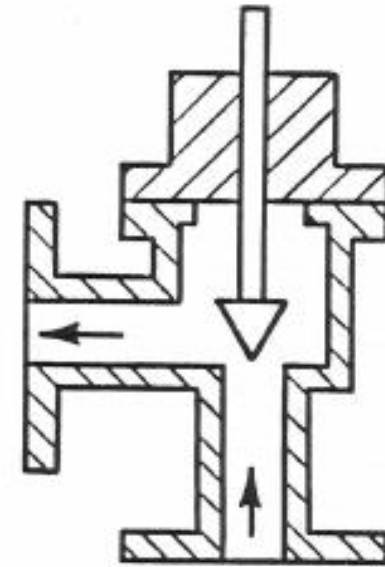

(c)

Angle



VALTEK

Mark One Flow Characteristics, Trim Types

Equal Percentage

Equal percentage is the characteristic most commonly used in process control. The change in flow per unit of valve stroke is directly proportional to the flow occurring just before the change is made. While the flow characteristic of the valve itself may be equal percentage, most control loops will produce an installed characteristic approaching linear when the overall system pressure drop is large relative to that across the valve.

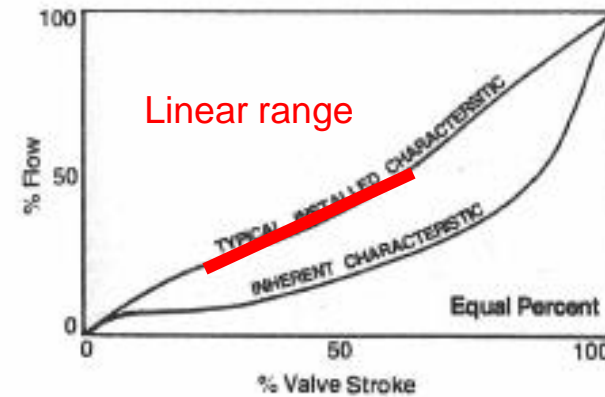

Linear

Linear inherent characteristic produces equal changes in flow per unit of valve stroke regardless of plug position. Linear plugs are used on those systems where the valve pressure drop is a major portion of the total system pressure drop.

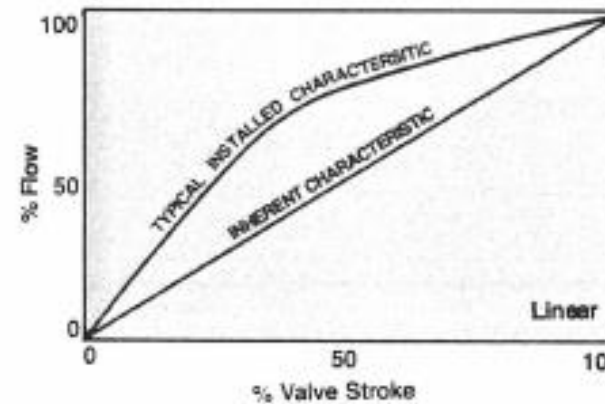

Quick Open

Quick open plugs are used for on-off service and are primarily designed to produce maximum flow quickly.

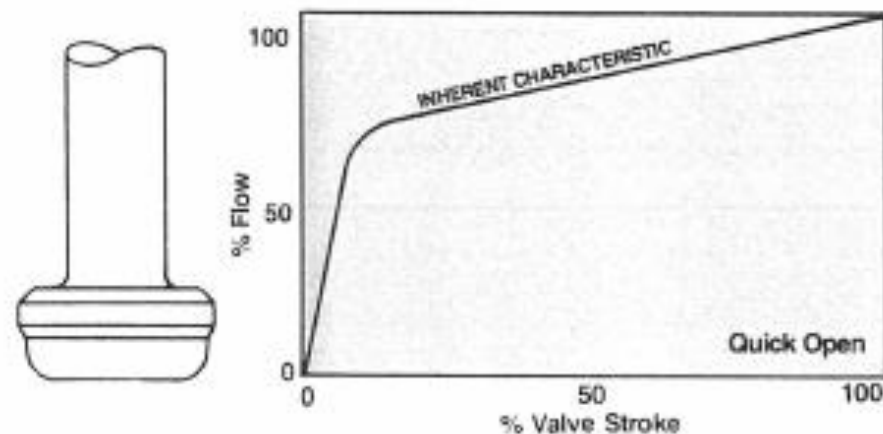

Trim Types

Three different trim types are available: Standard full area trim provides maximum C_v with a removable seat ring. Reduced trim is available in a wide variety of sizes when lower C_v 's and large bodies are required. Integral trim uses a special seat machined into the body and an oversized plug to provide additional C_v beyond the capabilities of standard trim.

Mark One valves can be converted from one trim type to another since all seat rings and plugs within a given size and pressure class are completely interchangeable. Integral trim is available by removing the seat ring and by changing the plug.

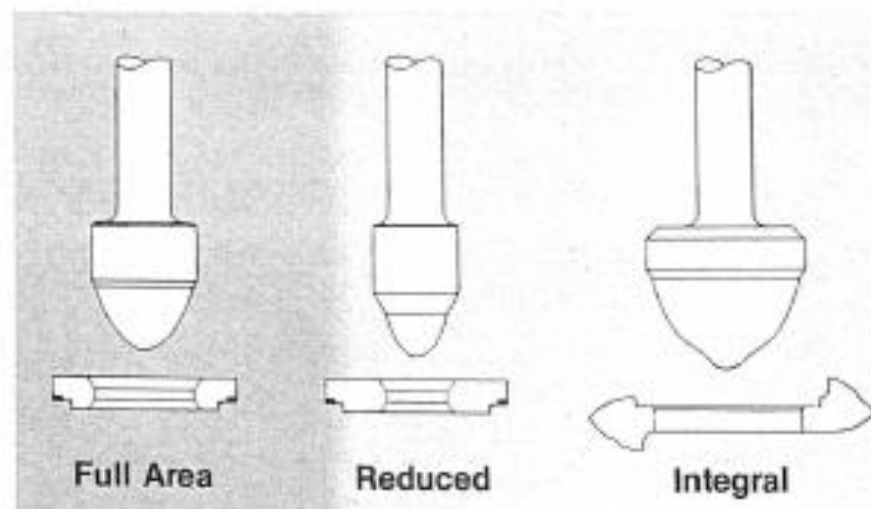

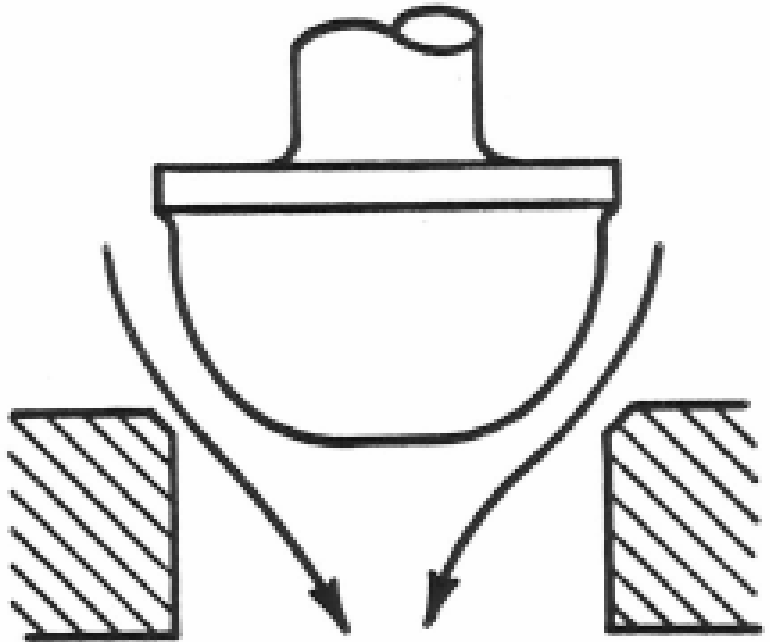

Parabolic

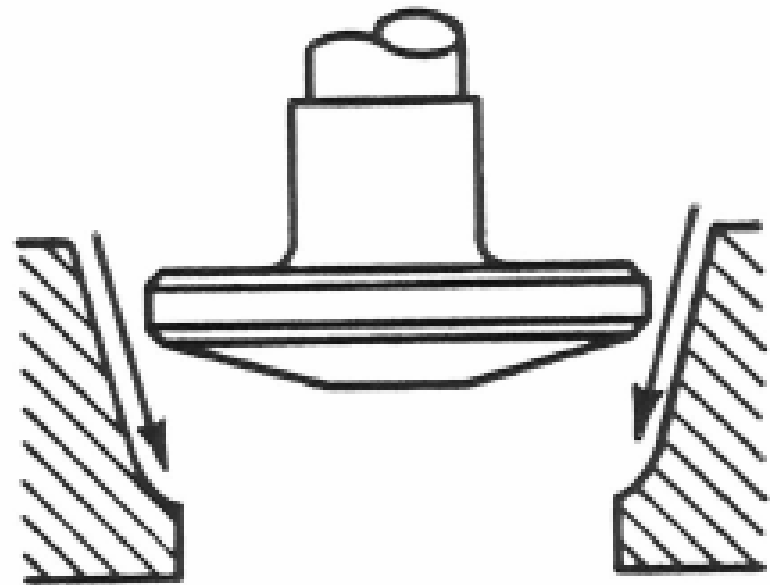

Quick-opening

C_v 's for an Equal Percentage Valve

Table 2.1 Representative C_v 's for an Equal Percentage Globe Valve.

	Body Size (in)	Stem Position as a Percentage of Total Travel									
		10	20	30	40	50	60	70	80	90	100
C_v	1	0.79	1.25	1.80	2.53	3.63	5.28	7.59	10.7	12.7	13.2
	1.5	0.80	1.23	1.91	2.95	4.30	6.46	9.84	16.4	22.2	28.1
	2	1.65	2.61	4.30	6.62	11.1	20.7	32.8	44.7	50.0	53.8
	3	3.11	5.77	9.12	13.7	21.7	36.0	60.4	86.4	104	114
	4	4.90	8.19	13.5	20.1	31.2	52.6	96.7	140	170	190

(from *Chemical Process Control*, by J. B. Riggs, Ferret Publ., 2001)

Valve Design Equation

$$q = C_v f(l) \sqrt{\frac{\Delta P_v}{g_s}}$$

Valve Design Logic Diagram

Goal: Control q by changing l

