

Distillation Control

Class 41

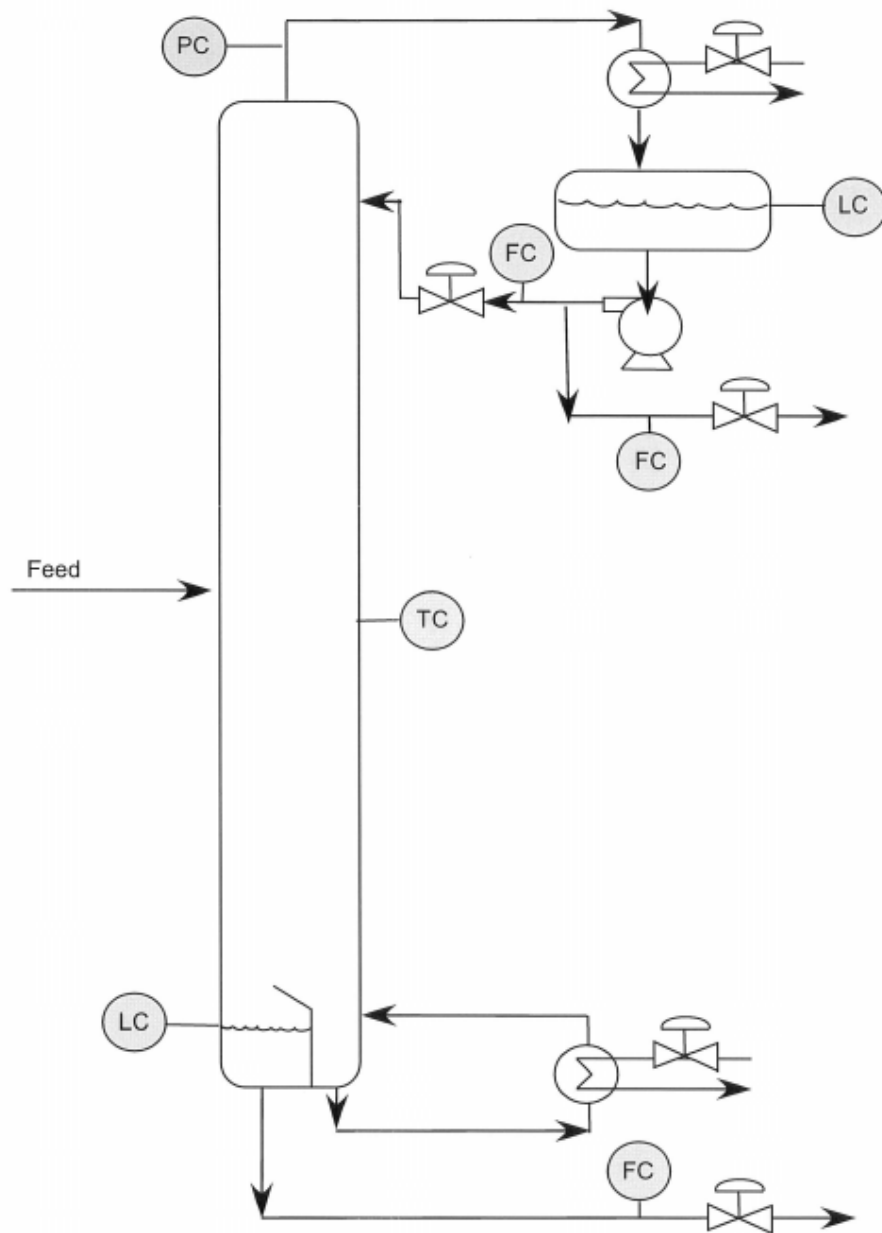

- How many valves?
- How many measurements possible?
- Wanted:
 - 5 controlled variables
 - 5 manipulated streams

Different Control Options

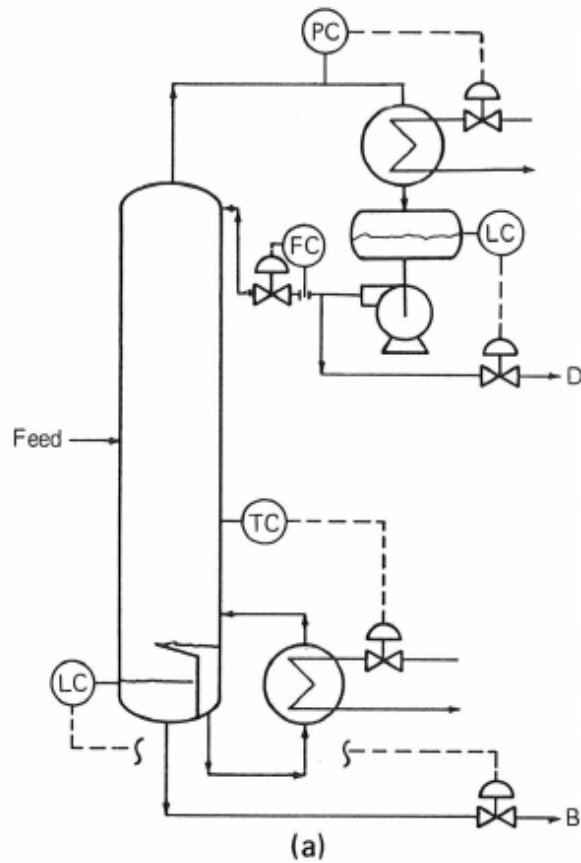

a. Indirect control, composition regulates boilup

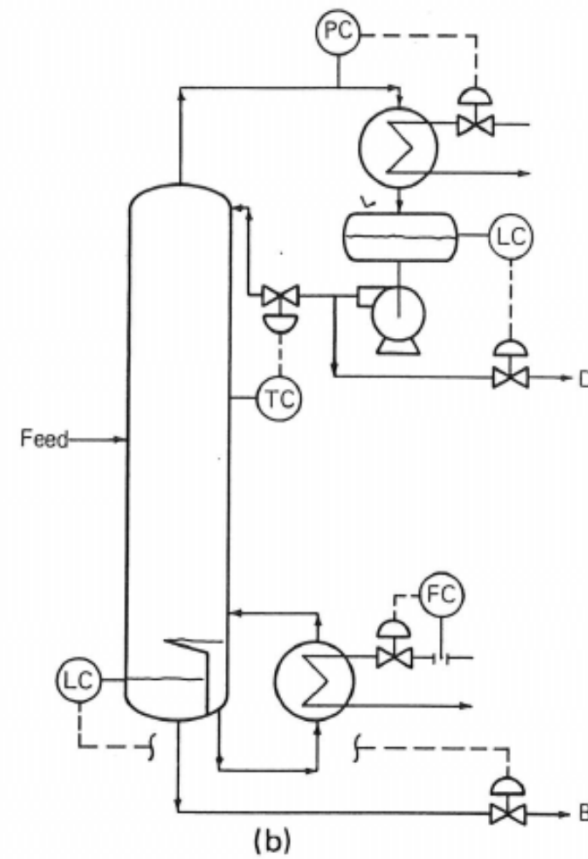

b. Indirect control, composition regulates reflux

Different Control Options (cont.)

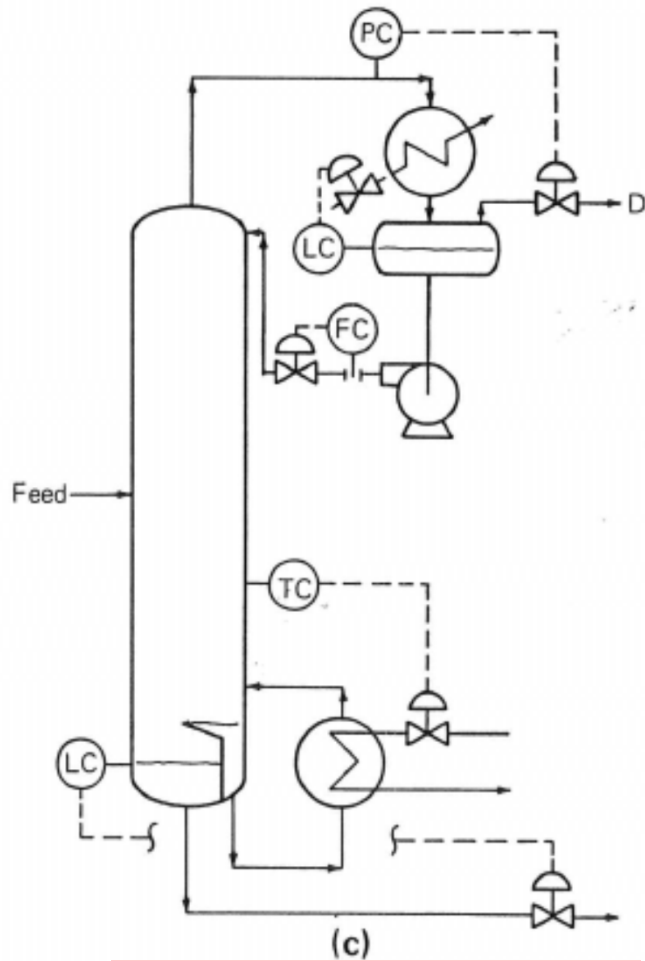

c. Same as (a) but with a vapor product

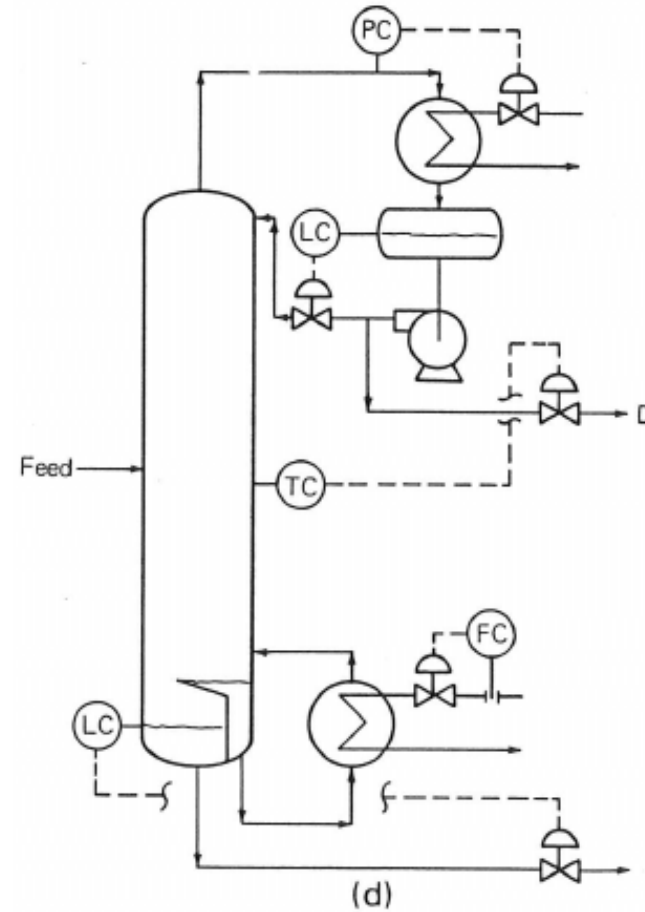

d. Direct control, composition regulates distillate flow

One more

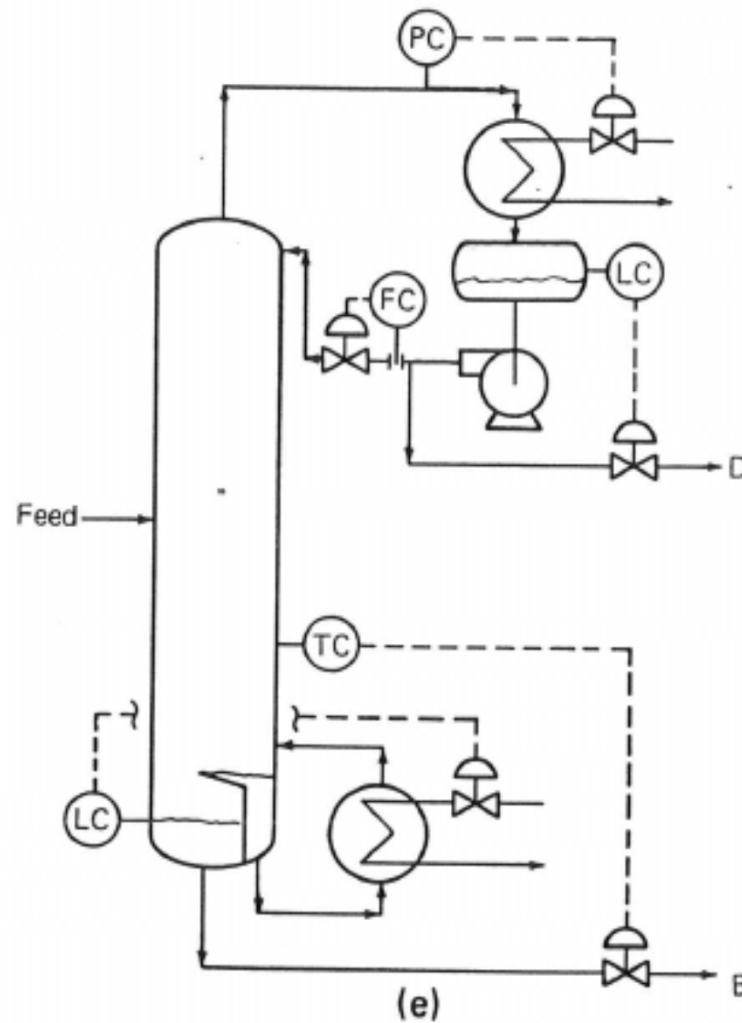

e. Direct control, composition regulates bottom flow

Response to Disturbance: Increased Light Components in Feed

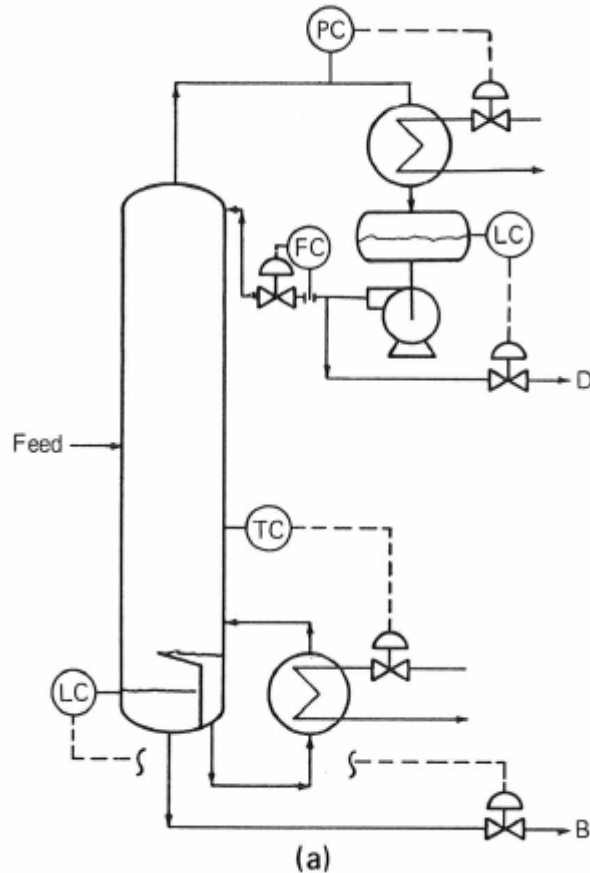

1. T decreases in tray where T sensor is located
 - Each tray is at boiling point
 - $T_{\text{boil}} \downarrow$ with increased lights
2. T sensor/controller increases steam, increasing boilup
3. Increased boilup raised T, raising P_{vap} , increasing P_{tot}
4. Pressure controller sees $P \uparrow$, so it increases condensation
5. Increased condensation increases level in reflux drum
6. Level controller increases distillate to maintain level control
7. Increased boilup lowers bottoms level
8. Level controller lowers bottoms flow rate

a. Indirect control, composition regulates boilup

All in all, when lights in feed \uparrow , we get $D \uparrow$, $B \downarrow$, which is what we wanted!!!

Also, $Q_{\text{reboiler}} \uparrow$ to vaporize increased lights
 $Q_{\text{condenser}} \uparrow$ to condense increased lights

Temperature in Distillation Column

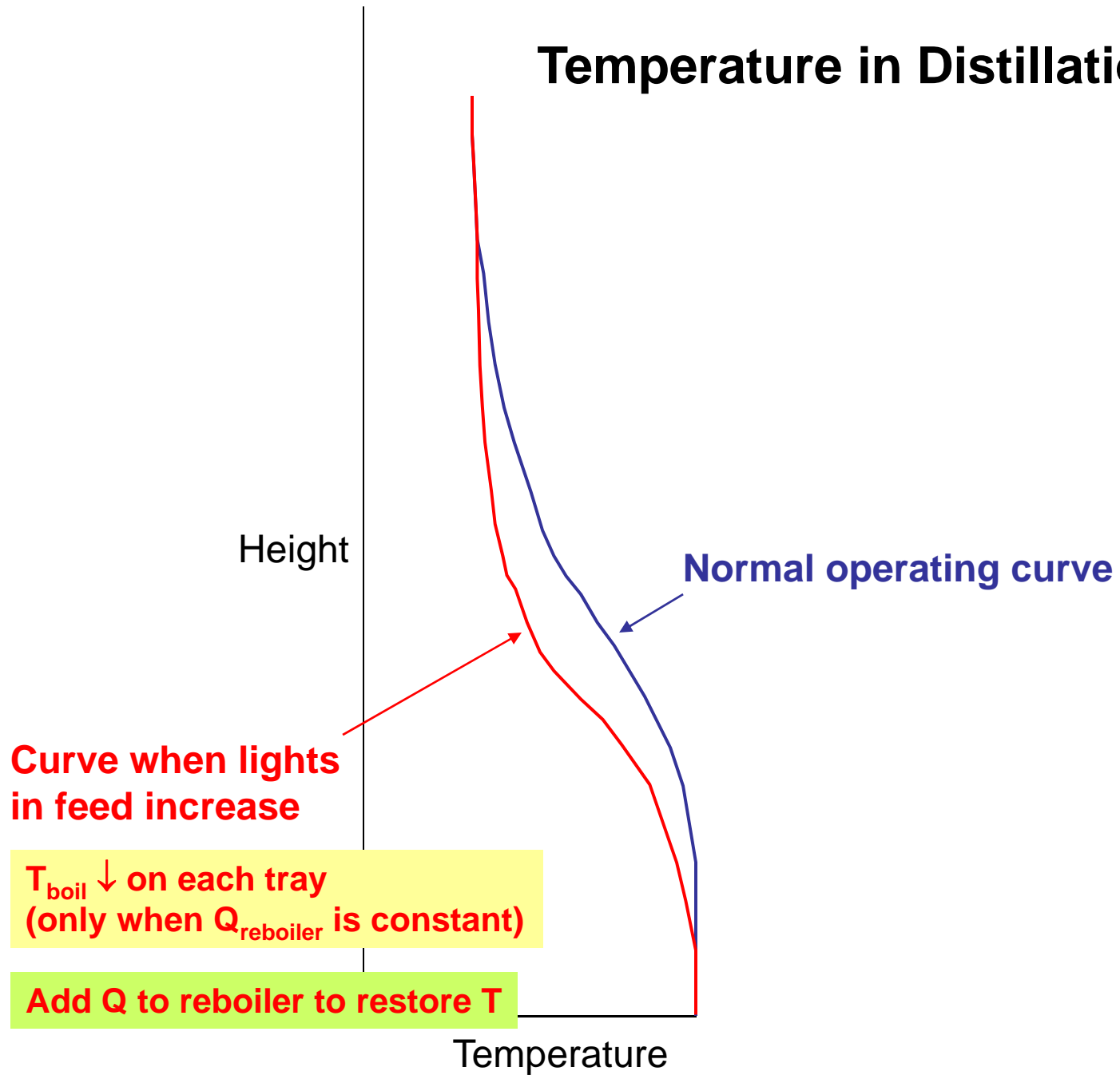

Response to Disturbance: Increased Light Components in Feed

1. T decreases in tray where T sensor is located
2. Reflux rate reduced
3. Level \uparrow in reflux drum
4. Distillate flow rate \uparrow
5. Lower level in bottoms
6. Decreased bottoms flow rate

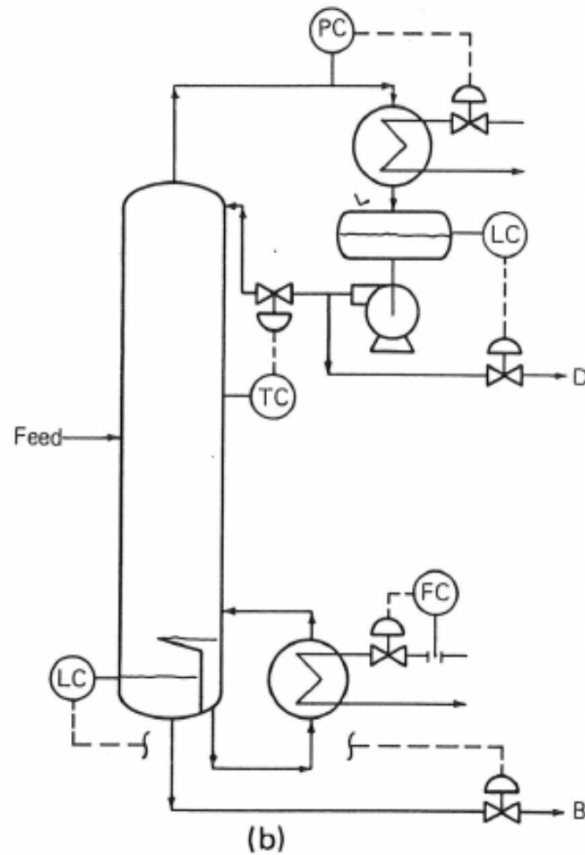

Pressure: not as clear

Reboiler rate?

b. Indirect control, composition regulates reflux

Response to Disturbance: Increased Light Components in Feed

1. T decreases in tray where T sensor is located
2. Distillate flow increased
3. Level in reflux drum \downarrow
4. Level controller (LC) reduces reflux flow rate
5. Bottoms level reduced due to lower reflux
6. Bottoms level controller reduces bottoms flow rate

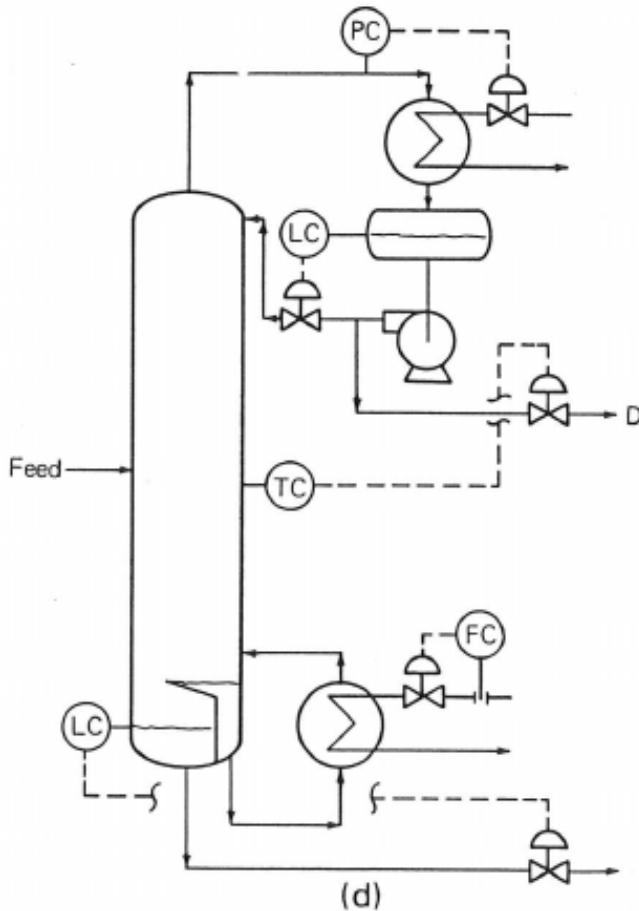

d. Direct control, composition regulates distillate flow

Pressure: not as clear

Reboiler rate?