

ChE 436
Process Dynamics and Control

Offset

Definition: $\text{offset} = y_{\text{set point}}(t) - y(t)$ (as $t \rightarrow \infty$)

Remember that offset is defined in the time domain, but can be calculated in the Laplace domain. An easy way to find the offset is to apply the final value theorem, assuming the limit exists, as follows:

$$\text{offset} = \lim_{s \rightarrow 0} [s \cdot \{Y_{sp}(s) - Y(s)\}]$$

where Y_{sp} and Y are the set point and controlled variable in the Laplace domain. The evaluation of the above equation depends on whether a change in set point or load occurs. The following relationships are useful when you have the expressions for Y/D (i.e., $G_D(s)$) and Y/Y_{sp} (i.e., $G_p(s)$) from the block diagram.

Load (Disturbance) Change

When there is only a disturbance change, the set point remains constant and therefore $Y_{sp} = 0$ (in deviation variables). Thus,

$$\text{offset} = \lim_{s \rightarrow 0} [-s \cdot Y(s)]$$

If there is a step change of magnitude M in the disturbance (no set point change) then:

$$\text{offset} = \frac{M}{s} \lim_{s \rightarrow 0} [-s \cdot Y(s)] = -M \lim_{s \rightarrow 0} [G_D(s)] \quad (\text{can you prove this?})$$

Set Point Change

When there is a set point change, then Y_{sp} is no longer 0 and must be determined depending on the type of change made.

If there is a step change of magnitude M in the set point (no disturbance change) then:

$$\text{offset} = \lim_{s \rightarrow 0} \left[s \cdot \left\{ \frac{M}{s} - Y(s) \right\} \right] = M - \lim_{s \rightarrow 0} \left[s \cdot \frac{M}{s} G_p(s) \right] = M \cdot [1 - \lim_{s \rightarrow 0} \{G_p(s)\}]$$

(can you prove this?)

If Y/Y_{sp} can be represented as a first order process (i.e. $Y/Y_{sp} = K_{cl}/(\tau_{cl}s+1)$) then:

$$\text{offset} = M(1 - K_{cl})$$

Example Problem

11.5: A control system has the following transfer functions:

$$G_c = 1$$

$$G_v = 2$$

$$G_p = G_d = 2/(s(s+1))$$

$$G_m = K_m = 1$$

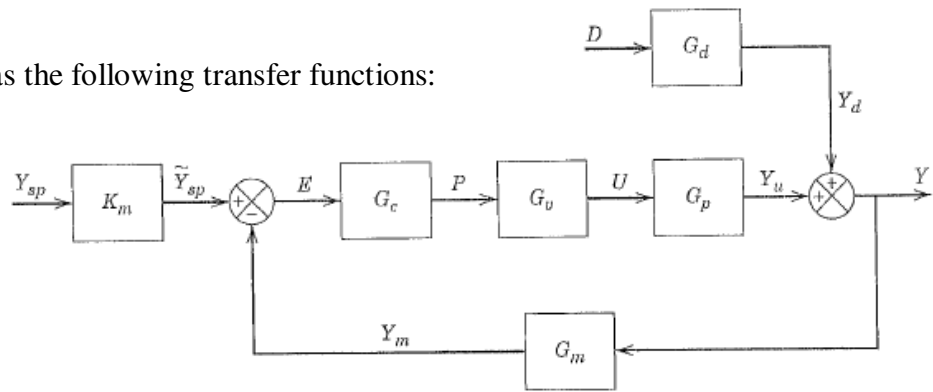

Figure 11.8 Standard block diagram of a feedback control system.

For a unit step change in Y_{sp} , determine:

a) $Y(s)/Y_{sp}(s)$

b) $y(\infty)$

c) Offset (note proportional controller)

d) $y(0.5)$

e) if the closed-loop response is oscillatory

f) Repeat parts a and c for $G_p = G_d = 2/(s+1)$